



FM Approvals
1151 Boston Providence Turnpike
P.O. Box 9102 Norwood, MA 02062 USA
T: 781 762 4300 F: 781-762-9375 www.fmapprovals.com

Member of the FM Global Group

CERTIFICATE OF COMPLIANCE

HAZARDOUS LOCATION ELECTRICAL EQUIPMENT PER CANADIAN REQUIREMENTS

This certificate is issued for the following equipment:

9162/13-11-1a, Transmitter Supply Unit with Limit values

NI/I/2/ABCD/T4 Ta = 70°C

AIS/I, II, III/1/ABCDEFG; 9162 6 031 001 1; Entity

I/2/AEx nAC [ia]/IIC/T4 Ta = 70°C; 9162 6 031 001 1; Entity

a = Special function: 2, 4

Entity Parameters:

2-wire Transmitter (Pins 11,12) ; Voc = 27VDC, Isc = 87.9mA, Po = 574mW, Ca = 90nF, La = 2.3mH,
3-wire Transmitter (Pins 10,11,12); Voc = 27VDC, Isc = 88.3mA, Po = 574mW, Ca = 90nF, La = 2.3mH,
Active Current Source (Pins 10, 11); Voc = 4.1VDC, Isc = 0.41mA, Po = 0.43mW, Ca = 100µF, La = 1H

Special conditions of Use:

1. Shall be installed in compliance with the enclosure, mounting, spacing and segregation requirements of the ultimate application including access only by the use of a tool.

9162/13-11-6a, Transmitter Supply Unit with Limit values

NI/I/2/ABCD/T4 Ta = 70°C

I/2/AEx nAC /IIC/T4 Ta = 70°C; 9162 6 031 002 1

a = Special function: 2, 4

Special conditions of Use:

1. Shall be installed in compliance with the enclosure, mounting, spacing and segregation requirements of the ultimate application including access only by the use of a tool.

9180/ab-77-11, Resistance Isolator

NI/I/2/ABCD/T4 Ta = 70°C

AIS/I, II, III/1/ABCDEFG; 9180 6 031 001 1; Entity

I/2[0]/Ex nAnC [ia] IIC T4 Ta = 70°C; 9180 6 031 001 1; Entity

a = Channels: 1 or 2

b = Measuring Range: 0 or 1



Member of the FM Global Group

Entity Parameters:

Voc = 6.5VDC, Io (Isc) = 16.5mA, Po = 27mW, Co = 25 μ F, Lo = 120mH,
Special Conditions of Use

1. *Shall be installed in compliance with the enclosure, mounting, spacing and segregation requirements of the ultimate application.*

9146/a0-1b-1c, Frequency Transmitter

NI/II/2/ABCD/T4 Ta = 70°C

AIS/I, II, III/1/ABCDEFG; 9146 6 031 001 1; Entity

I/2[0]/Ex nAnC[ia] IIC T4 Ta = 70°C; 9146 6 031 001 1; Entity

a = contact limits: 1 or 2

b = Analog /Digital Output: 0, 1, 5, or 9

c = Channels: 1 or 2

Entity Parameters:

Voc = 10.5VDC, Isc = 23.4mA, Po = 61.4mW Ca = 2.41 μ F, La = 63mH

Special Conditions of Use

1. *The Frequency Transmitter shall be installed in compliance with the enclosure, mounting, spacing and segregation requirements of the ultimate application.*

9186/12-11-1a, Fiber Optic Isolating Repeater NI/II/2/ABCD/T4 Ta = 65°C

AIS/I, II, III/1/ABCDEFG; 9186 6 031 001 1; Entity

I/1[0]/Ex e m ib [ja op is] IIC T4 Ta = 65°C; 9186 6 031 001 1; Entity

a = Fault Monitoring: 0 or 1.

Entity Parameters:

Fault Monitoring Circuit; Ui (Vmax) = 24VDC, li (Imax) = 600mA, Ci = 0, Li = 0

IS Bus Interface Uo (Voc) = 3.7VDC, Io (Isc) = 148mA, Po = 137mW, Co = 100 μ F, Lo = 1.3mH,

Ui (Vmax) \pm 4.2VDC, li (Imax) = 150mA, Pi = 140mW, Ci = 0, Li = 0

Special Conditions of Use

1. *The Fiber Optic Isolating Repeater shall be installed in compliance with the enclosure, mounting, spacing and segregation requirements of the ultimate application.*
2. *For Zone 1 installations the enclosure shall maintain mechanical retention for the power supply cable to provide strain relief.*

Equipment Ratings:

Nonincendive for Class I, Division 2, Groups A, B, C, D, and Class I, Zone 2 Groups IIC with intrinsically safe outputs for connections to Class I, II, III, Division 1, Groups A, B, C, D, E, F, G and Class I, Zone 0, Group IIC Hazardous (Classified) Locations when installed per manufacturer's control drawings.

Nonincendive for Class I, Division 2, Groups A, B, C, D, and Class I, Zone 2 Groups IIC Hazardous (Classified) Locations



Nonincendive for Class I, Division 2, Groups A, B, C, D, with intrinsically safe outputs for connections to Class I, II, III, Division 1, Groups A, B, C, D, E, F, G Hazardous (Classified) Locations when installed per manufacture's control drawings.

Increased safety, encapsulated and fiber optical interfaces protected Ex op is for use in Class I, Zone 1, Group IIC with intrinsically safe outputs for connections to Class I, Zone 0, Group IIC

Hazardous (Classified) Locations when installed per manufacture's control drawings.

FM Approved for:

R. STAHL Schaltgeraete GmbH
Am Bahnhof 30
D-74638 Waldenburg (Wurt.) Germany



This certifies that the equipment described has been found to comply with the following Approval Standards and other documents:

CSA-C22.2 No. 157	2002
CSA C22.2 No. 142	1993
CSA-C22.2 No. 213	1987
CAN/CSA-E60079-0:02	2002
CAN/CSA-E60079-11:02	2002
CAN/CSA E60079-18	2004
CAN/CSA-E79-7-95	1995

Original Project ID: 3017145

Canadian Project ID: 3027620C

Approval Granted: September 21, 2006

Subsequent Revision Reports / Date Approval Amended

Report Number	Date	Report Number	Date
3031658	November 21, 2007		
091209	February 10, 2010		

FM Approvals LLC

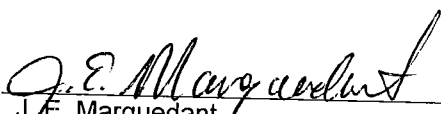

J.E. Marquedant
Group Manager, Electrical

10 February 2010
Date

The copying, distribution and utilization of this document as well as the communication of its contents to others without expressed authorization is prohibited. Offenders will be held liable for the payment of damages. All rights reserved in the event of the grant of a patent, utility model or ornamental design registration.

Weitergabe sowie Vervielfältigung dieses Dokuments, Verwertung und Mitteilung seines Inhalts sind verboten, soweit nicht ausdrücklich gestattet. Zuwiderhandlungen verpflichten zu Schadensersatz. Alle Rechte für den Fall der Patent-, Gebrauchsmuster- oder Geschmacksmustereintragung vorbehalten.

The Frequency Transmitter Type 9146 is an associated apparatus as well as a nonincendive apparatus and provides intrinsically safe connections for one (or two) field devices located in Class I, II, III, Division 1, Group A-G or Class I, Zone 0 [AEx ia] Group IIC, hazardous locations according to NEC Article 504/505 as listed below.

Frequency Transmitter Type 9146/a0-1b-1c

- a = numeral 1 or 2 for number of channels
- b = numeral 0,1, 5 or 9 for analogue- / digital output
- c = numeral 1 or 2 for limit contact

Entity parameters for wiring configurations are as follows:

Terminal	V _{OC} [V]	I _{SC} [mA]	P _O [mW]	L _o CL.I, Div.1, A,B / Zone 0, GP.IIC	L _o CL.I, Div.1, C-G / Zone 0, GP.IIB	C _o CL.I, Div.1,A,B / Zone 0, GP.IIC	C _o CL.I, Div.1, C-G / Zone 0, GP.IIB	V _{max}	I _{max}
10, 11, 14, 15	10,5	23,4	61,4	63 mH	230 mH	2,41 µF	16,8 µF	-	-

Notes:

1. For Connections refer to chapter 7 of Operation instruction ID-No. 9146 6 031 001 0.
2. Intrinsically safe apparatus may be switches, thermocouples, LEDs, RTDs or an FM Approved System or Entity device connected in accordance with the manufacturer's installation instructions.
3. For Entity concept use the appropriate parameters to ensure the following:

V_t or $V_{OC} \leq V_{max}$	$C_o, C_a \geq C_i + C_{leads}$	$P_o \leq P_i$
I_t or $I_{SC} \leq I_{max}$	$L_o, L_a \geq L_i + L_{leads}$	
4. Electrical apparatus connected to an intrinsically safe system should not use or generate voltages > 250 V (U_{max}).
5. Installation should be in accordance with Article 504/505 of the *National Electrical Code*, ANSI/NFPA 70 and ANSI/ISA RP 12.06.01.
6. Installation in Canada should be in accordance with the Canadian Electrical Code, CSA C22.1, Part 1, Appendix F.
7. Use a general purpose enclosure meeting the requirements of ANSI/ISA S82.02.01 for use in non-hazardous or Class I, Division 2, hazardous (classified) locations.
8. Use an FM Approved Dust-ignition proof enclosure appropriate for environmental protection in Class II, Division 1, Groups E,F and G; and Class III, hazardous (classified) locations.
9. Each channel shall be installed within a separately shielded cable or a single cable with a separate shield for each channel.
10. These modules are to be mounted on DIN rail, DIN rail with pac-Bus (type 9194) or pac-Carrier (type 9195).The field wiring in any case is connected to the IS pac device terminals.
11. Ambient temperature: -20°C ... + 70°C (any mounting position)

Certification drawing

			2006	Date	Name	Title	Scale
			Drawn	24.05.	Einsiedler	Frequency Transmitter Type 9146	none
			Appr.		Kaiser		Sheet 1 of 1
						Drawing No.	Agency
01	19.09.06	Einsiedler				9146 6 031 001 1	FM
Index	Date	Drawn			Replaces:	Replaced by:	A4

The copying, distribution and utilization of this document as well as the communication of its contents to others without expressed authorization is prohibited. Offenders will be held liable for the payment of damages. All rights reserved in the event of the grant of a patent, utility model or ornamental design registration.

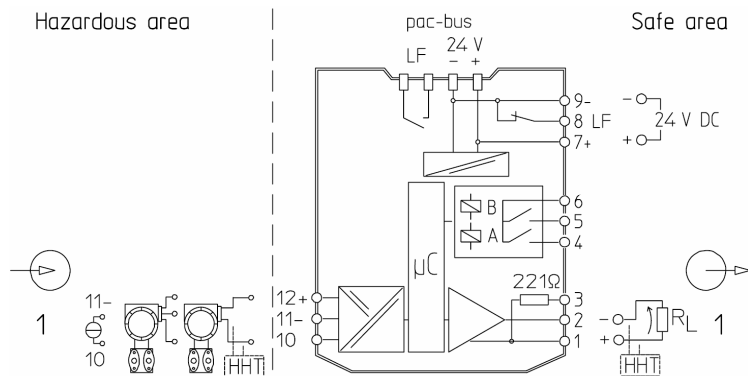

The Transmitter Supply Unit Type 9162/13-11-1* is an associated apparatus as well as a nonincendive apparatus for installation in non-hazardous, Class I, Division 2 or Zone 2 hazardous (Classified) Locations and provides intrinsically safe connections for one field device located in Class I, II, III, Division 1, Group A-G or Class I, Zone 1 [AEx ib] Group IIC, hazardous locations according to NEC Article 504/505 as listed below.

Hazardous area: Class I, II, III; Div. 1; Group A-G or Class I; Zone 1; Group IIC/IIB Hazardous Locations
 Safe area: Non-hazardous, Division 2 or Zone 2 Hazardous (Classified) Locations

Transmitter Supply Unit Type 9162/13-11-1f
 f = numeral 2 or 4 for special function

Entity parameters for wiring configurations are as follows:

	V_{OC} [V]	I_{SC} [mA]	P_O [mW]	L_o CL.I, Div.1, A,B / Zone 0, GP.IIC	L_o CL.I, Div.1, C-G / Zone 0, GP.IIB	C_o CL.I, Div.1,A,B / Zone 0, GP.IIC	C_o CL.I, Div.1, C-G / Zone 0, GP.IIB	V_{max} [V]	I_{max} [mA]
for 2-wire transmitter	27.0	87.9	574	2.3 mH	14 mH	90 nF	705 nF	-	-
for 3-wire transmitter	27.0	88.3	574	2.3 mH	14 mH	90 nF	705 nF	-	-
active current source	4.1	-	-	-	-	-	-	30	100

Notes:

- For Connections refer to chapter 7 of Operation instruction ID-No. 9162 6 031 001 0
- Intrinsically safe apparatus may be switches, thermocouples, LEDs, RTDs or an FM Approved System or Entity device connected in accordance with the manufacturer's installation instructions.
- For Entity concept use the appropriate parameters to ensure the following:
 V_t or $V_{OC} \leq V_{max}$ $C_o, C_a \geq C_i + C_{leads}$ $P_o \leq P_i$
 I_t or $I_{SC} \leq I_{max}$ $L_o, L_a \geq L_i + L_{leads}$
- Electrical apparatus connected to an intrinsically safe system should not use or generate voltages > 250 V (U_{max}).
- Installation should be in accordance with Article 504/505 of the National Electrical Code, ANSI/NFPA 70 and ANSI/ISA RP 12.06.01
- Installation in Canada should be in accordance with the Canadian Electrical Code, CSA C22.1, Part 1, Appendix F.
- Use a general purpose enclosure meeting the requirements of IEC 61010-1 for use in non-hazardous or Class I, Division 2, hazardous (classified) locations.
- Use an FM Approved Dust-ignition proof enclosure appropriate for environmental protection in Class II, Division 1, Groups E,F and G; and Class III, hazardous (classified) locations.
- Each channel shall be installed within a separately shielded cable or a single cable with a separate shield for each channel.
- These modules are to be mounted on DIN rail, DIN rail with pac-Bus (type 9194) or pac-Carrier (type 9195). The field wiring in any case is connected to the ISpac device terminals.
- Ambient temperature: -20 °C ... +70 °C (any mounting position)

Weitergabe sowie Vervielfältigung dieses Dokuments, Verwertung und Mitteilung seines Inhalts sind verboten, soweit nicht ausdrücklich gestattet. Zuwiderhandlungen verpflichten zu Schadenersatz. Alle Rechte für den Fall der Patent-, Gebrauchsmuster- oder Geschmacksmusterreife vorbehalten.

F 4830 503

			2006	Date	Name	Certification drawing	Scale
			Drawn by	24.05.	Einsiedler		none
			Checked		Danko		Sheet
						Transmitter Supply Unit with limit values Type 9162/13-11-1*	1 of 1
						9162 6 031 001 1	Agency
							FM
02	29.09.09	Reistle	STAHL				
01	19.09.06	Einsiedler					
Index	Date	Name	Rep. f.		Rep. t.		A4

Non-hazardous, Division 2 or Zone 2
Hazardous (Classified) Locations

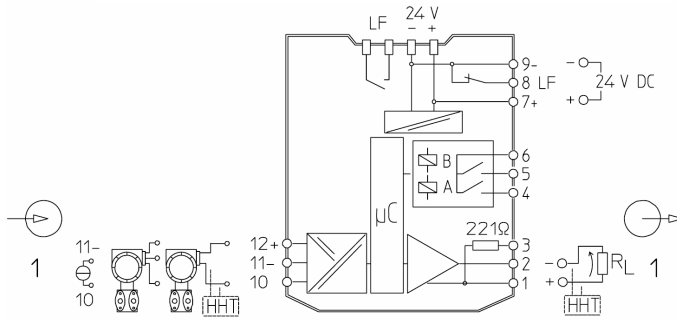

The Transmitter Supply Unit Type 9162/13-11-6* is a nonincendive apparatus located in a non-hazardous or Class I, Division 2 or Zone 2 hazardous location.

Transmitter Supply Unit Type 9162/13-11-6f
f = numeral 2 or 4 for special function

Electrical parameters for wiring configurations are as follows:

Function	Terminals	U _n (V DC)	I _n (mA DC)
Power Supply	7 (+); 9 (-) or pac-bus 1(+), 2(-)	24 (18 ... 31.2)	85
Output circuits	1, 2 (common), 3, 2 (common)	R _{load} < 600 Ω R _{load} < 350 Ω	0/4 to 20
Error indicator circuit, LF	8, 9 (-) or pac-bus 3, 4	30	100
Limit value contacts:	A 4, 6 (common) B 5, 6 (common)	± 30	100
Configuration Interface	plug connector V401 (accessible behind front cover)	± 15	10
Input circuit, passive 2-wire transmitter	12 (+), 11 (-)	16 V (@ 20mA)	0 to 20
Input circuit, passive 2-wire transmitter	12 (+), 10 (signal), 11 (-)	16 V (@ 20mA)	0 to 20
Input circuit, active current source	10 (+), 11 (-)	≤ 30 R _i = 30 Ω	≤100 0 to 20

Notes:

- For Connections refer to chapter 7 of Operation instruction ID-No. 9162 6 031 002 0.
- Installation should be in accordance with Article 501/505 of the National Electrical Code, ANSI/NFPA 70 and ANSI/ISA RP 12.06.01
- Installation in Canada should be in accordance with the Canadian Electrical Code, CSA C22.1, Part 1, Appendix F.
- Use a general purpose enclosure meeting the requirements of IEC 61010-1 for use in non-hazardous or Class I, Division 2, hazardous (classified) locations.
- Use an FM Approved Dust-ignition proof enclosure appropriate for environmental protection in Class II, Division 1, Groups E, F and G; and Class III, hazardous (classified) locations.
- These modules are to be mounted on DIN rail, DIN rail with pac-Bus (type 9194) or pac-Carrier (type 9195). The field wiring in any case is connected to the ISpac device terminals.
- Ambient temperature: -20 °C...+70 °C (any mounting position)

The copying, distribution and utilization of this document as well as the communication of its contents to others without expressed authorization is prohibited. Offenders will be held liable for the payment of damages. All rights reserved in the event of the grant of a patent, utility model or ornamental design registration.

Weitergabe sowie Vervielfältigung dieses Dokuments, Verwertung und Mitteilung seines Inhalts sind verboten, soweit nicht ausdrücklich gestattet. Zuwiderhandlungen verpflichten zu Schadensersatz. Alle Rechte für den Fall der Patent-, Gebrauchsmuster- oder Geschmacksmusteranmeldung vorbehalten.

F 4830 503

			2009	Date	Name	Certification drawing	Scale
			Drawn by	09.12.	Reistle		none
			Checked		Danko		Sheet
						Transmitter Supply Unit with limit values Type 9162/13-11-6*	1 of 1
						9162 6 031 002 1	Agency
							FM
Index	Date	Name				Rep. f.	Rep. t.
							A4



The copying, distribution and utilization of this document as well as the communication of its contents to others without expressed authorization is prohibited. Offenders will be held liable for the payment of damages. All rights reserved in the event of the grant of a patent, utility model or ornamental design registration.

Weitergabe sowie Vervielfältigung dieses Dokuments, Verwertung und Mitteilung seines Inhalts sind verboten, soweit nicht ausdrücklich gestattet. Zuwiderhandlungen verpflichten zu Schadenersatz. Alle Rechte für den Fall der Patent-, Gebrauchsmuster- oder Geschmacksmodellrechte vorbehalten.

The Resistance Isolator Type 9180 is an associated apparatus as well as a nonincendive apparatus and provides intrinsically safe connections for one (or two) field devices located in Class I, II, III, Division 1, Group A-G or Class I, Zone 0 [AEx ia] Group IIC, hazardous locations according to NEC Article 504/505 as listed below.

Resistance Isolator Type 9180/ab-77-11

a = numeral 1 or 2 for number of channels
 b = numeral 0 or 1 for measuring range

Entity parameters for wiring configurations are as follows:

Terminal 10 - 15	V _{OC} [V]	I _{SC} [mA]	P _O [mW]	L _o CL.I, Div.1, A,B / Zone 0, GP.IIC	L _o CL.I, Div.1, C-G / Zone 0, GP.IIB	C _o CL.I, Div.1,A,B / Zone 0, GP.IIC	C _o CL.I, Div.1, C-G / Zone 0, GP.IIB	V _{max}	I _{max}
Any combination	6,5	16,5	27	120 mH	450 mH	25 µF	570 µF	-	-

Notes:

- For Connections refer to chapter 7 of Operation instruction ID-No. 9180 6 031 001 0
- Intrinsically safe apparatus may be switches, thermocouples, LEDs, RTDs or an FM Approved System or Entity device connected in accordance with the manufacturer's installation instructions.
- For Entity concept use the appropriate parameters to ensure the following:

$$V_t \text{ or } V_{OC} \leq V_{max} \quad C_o, C_a \geq C_i + C_{leads} \quad P_o \leq P_i$$

$$I_t \text{ or } I_{SC} \leq I_{max} \quad L_o, L_a \geq L_i + L_{leads}$$
- Electrical apparatus connected to an intrinsically safe system should not use or generate voltages > 250 V (U_{max}).
- Installation should be in accordance with Article 504/505 of the National Electrical Code, ANSI/NFPA 70 and ANSI/ISA RP 12.06.01
- Installation in Canada should be in accordance with the Canadian Electrical Code, CSA C22.1, Part 1, Appendix F.
- Use a general purpose enclosure meeting the requirements of ANSI/ISA S82.02.01 for use in non-hazardous or Class I, Division 2, hazardous (classified) locations.
- Use an FM Approved Dust-ignition proof enclosure appropriate for environmental protection in Class II, Division 1, Groups E, F and G; and Class III, hazardous (classified) locations.
- Each channel shall be installed within a separately shielded cable or a single cable with a separate shield for each channel.
- These modules are to be mounted on DIN rail, DIN rail with pac-Bus (type 9194) or pac-Carrier (type 9195). The field wiring in any case is connected to the IS pac device terminals.
- Ambient temperature: -20 °C ... +70 °C (any mounting position)

F 4830 510

				Certification drawing			
			2006	Date	Name	Title	Scale
			Drawn	24.05.	Einsiedler	Resistance Isolator Type 9180	none
			Appr.		Kaiser		Sheet 1 of 1
						Drawing No.	Agency
01	19.09.06	Einsiedler				9180 6 031 001 1	FM
Index	Date	Drawn	Replaces:		Replaced by:		A4

Type 9186/12-.1-1.

Auxiliary power input	Function	Terminal
24 V dc (20 V ... 35 V dc)	+ 24 V	1
67 mA (at 24 V)	0 V	2

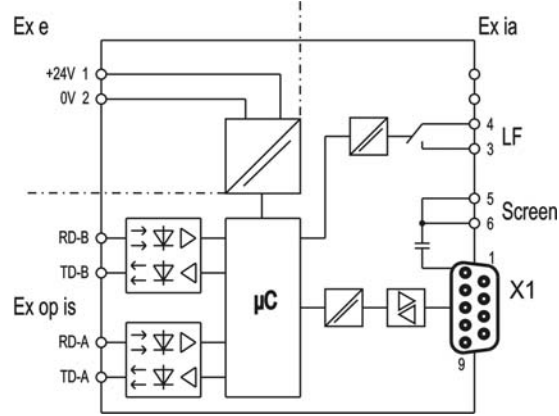

Ex ia and Ex op is circuits for use in: Class I, II, III; Div. 1; Group A-G or Class I; Zone 0; Group IIC/IIB Hazardous Locations
 Installation of apparatus in: Non-hazardous, Class I, Div. 2, Class I, Zone 1 Hazardous (Classified) Locations

The Fiber Optic Isolating Repeater Type 9186 is an explosion protected apparatus for installation in Class I, Zone 1 or Class I, Div. 2 hazardous (Classified) locations and provides intrinsically safe connections for field circuits located in Class I, II, III, Division 1, Group A-G or Class I, Zone 0 [Aex/Ex ia] Group IIC and optical intrinsically safe connections for circuits located in Class I, II, III, Division 1, Group A-G or Class I, Zone 0 [Aex/Ex op is] Group IIC, hazardous (classified) locations according to NEC Article 504/505 as listed below.

Fiber Optic Isolating Repeater Type 9186/12-a1-1b

a = numeral 1 for optical interface 850nm

b = numeral 0 or 1 for fault monitoring: 0 – without; 1 - relay

Entropy parameters for wiring configurations are as follows

connector	V _{OC} [V]	I _{SC} [mA]	P _O [mW]	L _o	L _o	C _o	C _o	V _{max} [V]	I _{max}
				CL.I, Div.1, A,B / Zone 0, GP.IIC	CL.I, Div.1, C-G / Zone 0, GP.IIB	CL.I, Div.1,A,B / Zone 0, GP.IIC	CL.I, Div.1, C-G / Zone 0, GP.IIB		
X1	3.70	148	137	1,3 mH	7 mH	100 µF	1000 µF	± 4.2	-
LF	-	-	-	-	-	-	-	24	600
TD-A, TD-B	n.a.	n.a.	15 (optical)	n.a.	n.a.	n.a.	n.a.	n.a.	n.a.

Notes:

- Intrinsically safe apparatus may be switches, thermocouples, LEDs, RTDs or an FM Approved System or Entity device connected in accordance with the manufacturer's installation instructions.
- For Entity concept use the appropriate parameters to ensure the following:
 V_i or $V_{OC} \leq V_{max}$ $C_o, C_a \geq C_i + C_{leads}$ $P_o \leq P_i$
 I_t or $I_{SC} \leq I_{max}$ $L_o, L_a \geq L_i + L_{leads}$
- Electrical apparatus connected to an intrinsically safe system should not use or generate voltages > 250 V (U_{max}).
- If using in hazardous areas classified Zone 1 the Ex e terminals 1 and 2 for the power supply may not be connected or disconnected with the circuit electrically live. After switching off the supply voltage, wait 1 minute before disconnecting the cables from the unit. Use only insulated wire end ferrules. The insulations sleeves need to be fit into the opening of the terminal in order to ensure a minimum distance of 3mm between the conductive parts of the wires.
- Installation should be in accordance with Article 504/505 of the *National Electrical Code*, ANSI/NFPA 70 and ANSI/ISA RP 12.06.01
- Installation in Canada should be in accordance with the Canadian Electrical Code, CSA C22.1, Part 1, Appendix F.
- Use a certified enclosure meeting the requirements of the application for use in Class I, Zone 1 hazardous (Classified) Locations.
- Use a general purpose enclosure meeting the requirements of ANSI/ISA S82.02.01 for use in non-hazardous or Class I, Division 2, or Class I, Division 1, hazardous (Classified) locations.
- Use an FM Approved Dust-ignition proof enclosure appropriate for environmental protection in Class II, Division 1, Groups E, F and G; and Class III, hazardous (Classified) locations.
- Each channel shall be installed within a separately shielded cable or a single cable with a separate shield for each channel.
- These modules are to be mounted on DIN rail
- Ambient temperature: -20°C ... +65°C (any mounting position)

The copying, distribution and utilization of this document as well as the communication of its contents to others without expressed authorization is prohibited. Offenders will be held liable for the payment of damages. All rights reserved in the event of the grant of a patent, utility model or ornamental design registration.

Weitergabe sowie Vervielfältigung dieses Dokuments, Verwertung und Mitteilung seines Inhalts sind verboten, soweit nicht ausdrücklich gestattet. Zuwiderhandlungen verpflichten zu Schadensersatz. Alle Rechte für den Fall der Patent-, Gebrauchsmuster- oder Geschmackschutzregistrierung vorbehalten.

F 4830 503

			2007	Date	Name	Certification drawing Fiber Optic Isolating Repeater Type 9186 9186 6 031 001 1	Scale
			Drawn by	31.10.	Einsiedler		none
			Checked		Kaiser		Sheet 1 of 1
							Agency FM
Index	Date	Name				Rep. f.	Rep. t.
							A4

