



Technical and economical considerations

in regard to use of electrical equipment in hazardous areas of Zone 2

by Prof. Dr.-Ing. Ulrich Johannsmeyer, Dr.-Ing. Heribert Oberhem and Prof. Dr.-Ing. Hans Wehinger



Explosion-protected electrical equipment category 2 acc. to directive RL 94/9/EC for use in Zone 1 is available in a wide spectrum and in numerous designs on the market. Equipment category 3 for use in Zone 2 is comparatively rare for individual device types. In the chemical and petrochemical industry hazardous areas are recently increasingly classified as Zone 2. Even in places where formerly Zone 1 has been classified due to standardization nowadays as a result of growing cost pressure a less conservative classification of the hazardous zone became common practice. Typical examples for Zone-2-areas in the chemical and petrochemical industry are:

Outdoor installations with continuous process

- › natural ventilation
- › normally closed apparatuses, as well as installations with a high degree of automation, marked by:
 - › closed apparatuses
 - › closed exhaust system, as well as enclosed installations with technical ventilation.

As a current example, classification of hazardous areas of BASF AG may be used. Here one can see the significance of Zone 2 (Figure 1). From the size of the hazardous areas that have been classified into Zone 2, a bigger market of available equipment may be assumed. This seeming discrepancy becomes understandable from the historic development and the current technical re-

quirements specified by standardization. The old German regulations according to VDE 0165, for example, contained no detailed requirements for equipment for use in Zone 2; the essential prerequisites were ›good industrial quality‹ and ›not generating ignition sources under normal operating conditions‹. This partly led to the opinion that ›Zone 2-devices‹ are only ›half-explosion protected‹. Besides luminaries and big drives there were no noteworthy inquiries for special equipment for Zone 2.

In the course of harmonization and detailed definition of the European standardization standard EN 50021:1999, type of protection ›n‹ [1], has been developed in several steps. It described on almost 60 pages the requirements that resulted from the specifications of directive RL 94/9/EC: ›Equipment must be designed and constructed as to prevent foreseeable ignition sources which can occur during normal operation‹ (annex II 2.3).

With the aim of international harmonization of IEC and CENELEC, standard IEC-EN 60079-15:2005 [2] has been created, that describes on 80 pages an advanced requirement profile compared to the predecessor standard EN 50021 and that contains in many details the same technical requirements as standard EN 60079-0 [3] for apparatus for use in Zone 1. Ever since June 30, 2003 devices for use in Zone 2 may only be placed on the market when they additionally fulfill the requirements according to RL 94/9/EC and are marked as equipment of category 3G.

For the first time it is referred in IEC 60079-0:2007 [4], the newly introduced concept of ›Equipment Protection Level (EPL)‹ defines the protection level of equipment and installations. EPLs are in turn correlated with the known hazardous areas (Zone 0, 1, 2, for gases/vapours). In European Directive 94/9/EC the equipment categories are comparable to the EPLs. EPL ›Ga‹ corresponds here with category 1G, EPL ›Gb‹ corresponds with category 2G and EPL ›Gc‹ corresponds with category 3G. The protection concepts provided especially for EPL ›Gc‹ are listed in table 1.

With technical improvement of ›good industrial quality‹ and due to this development of standards, the technical distance for

equipment of category 3 – type of protection ›nc‹ – became smaller and smaller compared to the usual equipment of category 2.

In the following we want to show for which group of devices a separate line of devices for Zone 2 as a differentiation towards devices for Zone 1 would seem to make sense from today's point of view. For Zone 2 the question should be discussed what the easing towards the requirements on category 2 (Zone 1) is and what technical aspects should be in the foreground; market-specific factors especially on an international level may definitely lead to other conclusions. These considerations are mainly manufacturer-oriented, from the user's point of view the demand side is only regarded in some substantial technical parts.

Asynchronous motors

Drives in explosion-protected design with cage rotors are available in great quantities, especially in type of protection increased safety ›e‹. In the meantime requirements for mechanical parts in type of protection ›nc‹ for Zone 2 are analogous to the ones for type of protection ›e‹. Enormous simplification results from the fact that the blocked motor to be energized (short circuit) does not have to be taken into consideration in regard to safety for type of protection ›nc‹, because this would not be ›normal operation‹. This results in a simpler examination – no determination of t_E -time – and no certified motor protection is required. From the view of explosion-protection, the motor according to ›nc‹ due to this has reserve capacity compared to that according to ›e‹ but this reserve only has a technical and economical importance with a higher rated power. That is why type of protection ›nc‹ may rather be found in large-scale machines.

Installation technology

Control and distribution boxes for explosion-protected installations are required in great number. The enclosures, mainly made from plastics, have to fulfil high demands in regard to mechanical strength (impact test), degree of protection (IP 54) and material properties (e.g. climatic storage). Nowadays the normative specifications for ›nc‹ and ›e‹ are the same. The connecting parts have to fulfil the same requirements as well. So special terminals for ›nc‹ are not available. Clearance and creepage distances within the enclosure are reduced but this does not make for an essential economic advantage. All in all this shows only minimum savings potential.

Luminaires with fluorescent lamps

For explosion protection of linear luminaires with fluorescent lamps, the enclosure is an important component with requirements comparable to those for distribution boxes. Request for easy replacement of lamps requires additional expenditure to keep degree of protection IP 54, so that the total price for the luminaire is considerably determined by the enclosure. For enclosures of ›e‹ and ›nc‹ luminaires, the same requirements apply now; so ›good industrial quality‹ is topped by far. Ballasts in the ›nc‹-light fittings do not have to fulfill a separate type of protection (normal operation). Due to slightly increased requirements for some clearance and creepage distances, the use of standard-ballasts is not possible so that here a possible price advantage may not be utilized without problems. →

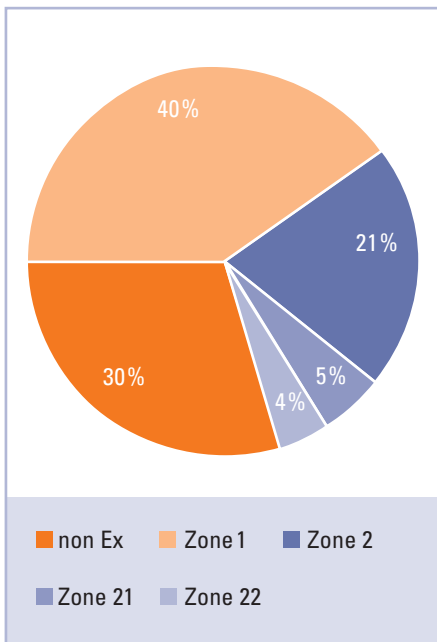

Figure 1: Part of production facilities of BASF AG (without office and common areas)

It is advantageous for operation of the lamp that the filaments in the »n«-light fitting do not have to be short-circuited like they have to be in the »e«-light fitting. So a longer service life of the lamp can be expected (pre-heating of filaments is possible) and ignition of the lamps is easier. It may be expected that because of this, requirements on the lamp holder would become less as well.

But in EN 60079-15 clause 21.2.4.4 it is required that »the contact pressure shall be adequate« and »the lamp holder shall be of a type designed to prevent sparking under conditions of vibration«. No test criteria are specified for this.

In case of a desired type examination according to »n« by a »notified body«, it seems obvious that the test engineer would resort to the tried and tested processes of type of protection »e« for lack of other criteria. So for the lamp holders this would mean »n« is similar to »e«.

All in all a linear luminaire with fluorescent lamps according to »n« only shows a slight technical simplification and has a hardly noticeable price advantage compared to the design according to »e« due to the similar enclosure and some fuzzy test criteria.

Switchgear

According to their purpose, switchgear spark under normal operating conditions and so are contrary to the usual characteristics of equipment according to type of protection »n«. Consequentially, a wide variance of protective measures and a series of very different test are suggested, beginning with paragraph 26 in EN 60079-15:2005. When switching capacities of the common installation technology are required, only the »non incandive component« with the limit values 254 V and 16 A or the »enclosed break device« with the limit values 690 V and 16 A re-

main. According to paragraph 33.4 of the stated standard type, tests including switching tests under explosive atmosphere have to be made and the external atmosphere must not ignite.

For the »non-incandive component« it has to be switched 50 times under normal operating conditions with 3 cycles, each with a new test mixture. For the »enclosed break device« the most unfavourable operating parameters have to be chosen (voltage, current, frequency, power factor) and the switching-on and switching-off test is done 10 times, each with a new test mixture. In a way these tests replace the requirements on material, clearances and routine test that are, in comparison, required of switching devices in type of protection flameproof enclosures »d«. But if you keep in mind that in a switching chamber of 20 cm³ the energy input of the burning test mixture is about 5 times smaller than the energy input during a half cycle with 690 V and 16 A, it seems doubtful that the criteria for switchgear for use in Zone 2 have any simplification compared to the proven solutions in flameproof enclosure. So it is not surprising that the ex-

tensive test facilities acc. to EN 60079-15 are normally not available at the »notified bodies« and that no series of switches according to this standard are obtainable.

Instrumentation and control devices(I&C)

Of all the protection concepts for Zone 2 in practice, nA (non-sparking), nL (energy-limited) and nR (restricted-breathing) are mainly applied. So protection concept nA is advantageous for use where under normal operating conditions no high surface temperatures (higher than the temperature class limits) and no switching sparks and arcs occur.

In the field of instrumentation and control technology, protection concept nL is utilized as well, especially where circuits are switched or plugged while energized (Table 2). Restricted-breathing enclosures also have to be used for built-in components that spark under normal operating conditions or for such built-in components with a high surface temperature, e.g. for chemical analysis devices.

EPL »Gc«	Intrinsic safety	»ic«	IEC 60079-11
	Encapsulation	»mc«	IEC 60079-18
	Non-sparking	»nA«	IEC 60079-15
	Restricted breathing	»nR«	IEC 60079-15
	Energy limitation	»nL«	IEC 60079-15
	Enclose-break device	»nC«	IEC 60079-15
	Pressurized enclosures	»pz«	IEC 60079-2

Table 1: Protection concepts for Equipment Protection Level (EPL) »Gc« (according to ATEX Directive 94/9/EC: category 3G)



Protection concept nA (non-sparking)

Principle of protection concept ›non-sparking‹ follows type of protection increased safety ›e‹. So it can only be used for equipment that do not feature sparks / electric arcs and has not hot surfaces during normal operation. Demands on nA-field devices according to EN 60079-15:2005 for instrumentation and control devices are specified specially in paragraph 23:

Paragraph 23 applies to ›Electronic and allied low power apparatus and sub-assemblies (typically less than or equal 20 W) used, for example, for measurement, control or communication purposes‹.

Devices of this kind have to:

- › have an enclosure with degree of protection IP 54 or they have to be fitted into an according protective enclosure,
- › have a rated or operating voltage ≤ 60 V AC or 75 V DC,
- › have facilities within or outside the device that limit the transients to 140% of the rated/operating voltage at the supply connections. Then requirements for clearance and creepage distances according to paragraph 6.7 do not apply!

For these devices it is assumed for Zone 2 that effective ignition sources only exist in case of faults.

This is accepted as being permissible because of the improbable coincidence with the presence of an explosive atmosphere.

Requirements for installation of nA-field devices

In installations with nA-field devices, use of standard-Ex ib-field devices is possible as well if the relevant nA-requirements are fulfilled. Marking in regard to intrinsic safety, however, should then be removed to avoid confusion with intrinsically safe installations and these devices should not be used as intrinsically safe devices later as well. But usually devices in normal industrial design are used that fulfill the requirements of paragraph 23 of EN 60079-15:2005.

Contrary to ic- or nL-installations direct connection to the I/O-interfaces of the automation system is possible here – even without special isolators. Wiring must not be blue as these are not intrinsically safe lines; the special requirements for the installation of intrinsically safe circuits do also not apply.

As a simplification the verifying that the electric limit values are kept (verification of intrinsic safety) can be dispensed with. But additionally a transients limitation – if required with additional measures – like transzorb-diodes or varistors – to 140% of the maximum operating voltage is required.

Protection concept ic/nL (intrinsic safety ic, energy limitation nL)

This is a protection concept that uses a simplified intrinsic safety. For Zone 2 no fault conditions are assumed, i.e. electrical parameters are regarded under the most unfavourable conditions that may occur during normal operation. For spark ignition only factor 1,0 is used instead of safety factor 1,5. Lesser requirements are also made on infallible clearance and creepage distances.

The essential requirements on the design of ic/nL-field devices according to IEC/EN 60079-11 [5] respectively EN 60079-15:2005 are:

- › in principle a design like ib- or ia-devices, but without fault analysis,
- › safety factor for spark ignition only 1,0, so 50% higher electrical values are possible,
- › marking like ib- or ia-devices (blue marking of cables, parameters that have to be specified U_0, I_0, P_0, L_0, C_0),
- › separation distance between connecting parts of intrinsically safe circuits among themselves 6 mm, towards earthed parts 3 mm,
- › may also be used for circuits switched under normal operating conditions (switches, pushbuttons, test bushings, plug connectors, etc.).

But devices of this type are difficult to find on the market.

Ex ib	Ex ic (nL)	Ex nA
(intrinsically safe for Zone 1)	(intrinsically safe for Zone 2, energy-limited)	(non-sparking) EN 60079-15
<ul style="list-style-type: none"> + Maintenance when energized + Use of standard equipment Ex i 	<ul style="list-style-type: none"> + Lower prices for special ic or nL I/Os + Maintenance when energized 	<ul style="list-style-type: none"> + Low-priced, often standard industrial equipment may be used + No verification of intrinsic safety
<ul style="list-style-type: none"> - Higher costs - Verification of intrinsic safety 	<ul style="list-style-type: none"> - Installation effort the same as for ib - Special ic/nL-equipment - Verification of intrinsic safety 	<ul style="list-style-type: none"> - Reservations in regard to maintenance - Limitation of transient voltage required

Table 2: Protection concept for I&C installations, advantages and disadvantages



Requirements for installations of ic/nL-systems

Here only the new IEC 60079-14:2008 [6] may be consulted as a basis, as the hitherto existing issues of requirements for installation EN 60079-14:2003 [7] did not contain specific requirements for ic/nL-systems. So here was a gap which the users filled differently according to their own best judgment. So there probably are many cases when nL-circuits have not been installed according to the rules of intrinsic safety. For the future the question arises here if there is requirement for modernization when the explosion protection documents are established or revised. At least when ic devices are to be used in future, the new requirements have to be utilized (please also see TRBS 2152 part 3 [8]):

- > as a basic principle intrinsically safe circuits of protection level ic are designed according to the same regulations that apply to ib und ia,
- > in future this also applies to nL according to IEC 60079-15,
- > marking obligation, if by colour, then light blue
- > cables and wires have to have a insulation test voltage conductor – earth, conductor – screen of 500 V AC or 750 V DC,
- > with strands the diameter of the individual wire has to be ≥ 0.1 mm,
- > for nL or ic circuits a verification of intrinsic safety has to be provided and documented.

A mixture of devices of types of protection nL and ic in one circuit is permitted. Here devices that are meant to be used in nL-circuits have to be mounted according to

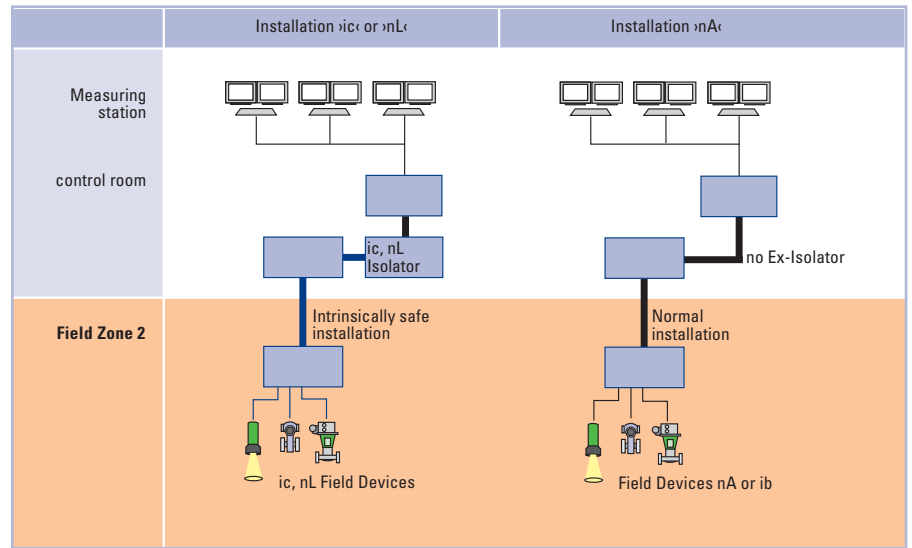

Figure 2: Point-to-point wiring in Zone 2

the regulations for intrinsically safe installations of type of protection ic. Devices that fulfill type of protection nL may correspondingly also be used in an intrinsically safe circuit in type of protection ic.

Comparison of installation concepts for instrumentation and control devices

In Figures 2 to 4 the different installation concepts for a point-to-point connection, for a remote I/O-system and for a fieldbus system are shown. The different requirements and concepts but also the close relation to Zone-1-installations can be seen.

All in all, in regard to classification into zones the following conclusions may be drawn: An installation especially for Zone 2 makes sense if

- > larger connected Zone 2-areas exist (no smaller Zone 1-islands) and if
- > a long-term classification for Zone 2 is ensured,
- > the cost-benefit ratio is significantly better than with 2G-equipment,
- > danger of confusion during maintenance is excluded,
- > and availability of 3G-equipment is ensured.

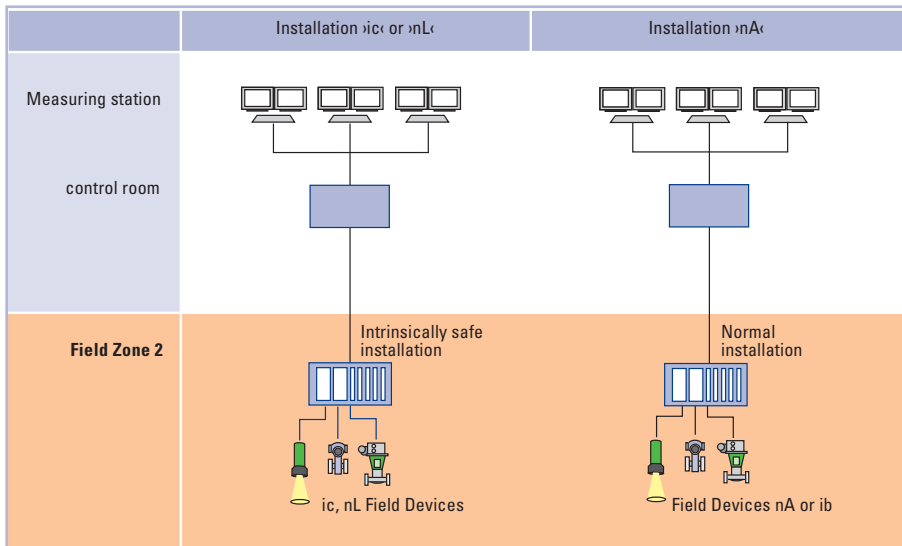

Figure 3: Remote I/O installation in Zone 2

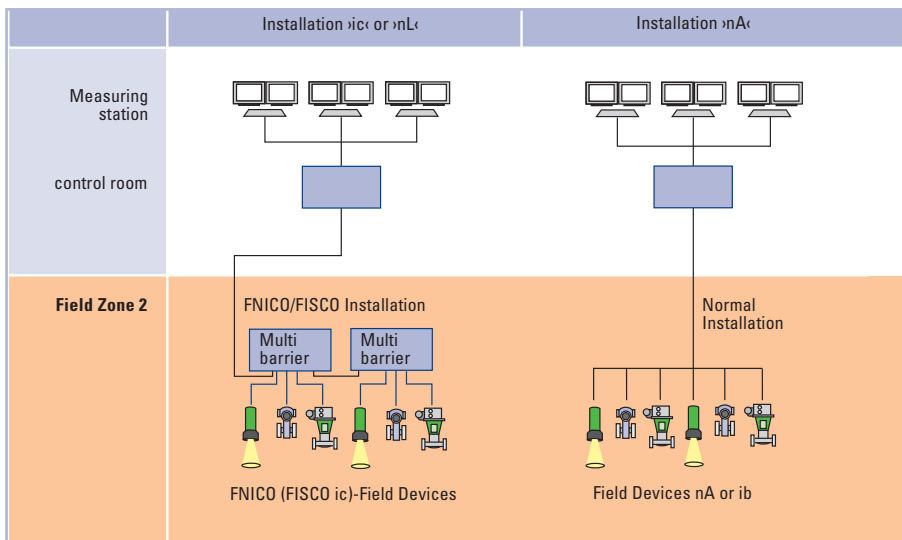

Figure 4: Fieldbus installation in Zone 2

References

- [1] EN 50021: 1999 Electrical apparatus for explosive atmospheres: Type of protection »n«
- [2] EN 60079-15: 2005 Electrical apparatus for potential explosive atmospheres, Part 15: Construction, test and marking of type of protection »n« electrical apparatus
- [3] EN 60079-0: 2006, Electrical apparatus for potential explosive atmospheres, Part 0: General requirements
- [4] IEC 60079-0: 2007 Explosive Atmospheres – Part 0: Equipment-General requirements
- [5] EN 60079-11: 2007 Explosive Atmospheres – Part 11: Equipment protection by intrinsic safety
- [6] IEC 60079-14: 2008 Explosive atmospheres – Part 14: Electrical installations design, selection and erection
- [7] EN 60079-14: 2003 Electrical apparatus for explosive gas atmospheres, Part 14: Electrical installation in hazardous areas (other than mines)
- [8] Technische Regeln für Betriebssicherheit TRBS 2152 Gefährliche explosionsfähige Atmosphäre, Teil 3: Vermeidung der Entzündung gefährlicher explosionsfähiger Atmosphäre