

Extended Parameter Set

for

IS1 Remote I/O System



Extended Parameter Set for IS1 Remote I/O System

| | | |
|-------|--|----|
| 1 | Overview..... | 3 |
| 1.1 | New features with the Extended Parameter Set..... | 3 |
| 1.2 | Selection of the IS1 Parameter Set..... | 4 |
| 1.3 | Mix of IS1 field stations with different parameter sets..... | 4 |
| 2 | System requirements..... | 5 |
| 3 | Compatibility with existing IS1 modules..... | 6 |
| 4 | Functional description..... | 7 |
| 4.1 | Telegram lengths with PROFIBUS DP..... | 7 |
| 4.2 | Telegram lengths with MODBUS RTU..... | 7 |
| | Group alarm / field station status..... | 8 |
| 4.2.1 | Control register CPM..... | 8 |
| 4.2.2 | Status register CPM..... | 8 |
| 4.3 | HART variables..... | 9 |
| 4.3.1 | Module selection in GSD file / I.S. Wizard..... | 9 |
| 4.3.2 | Data format..... | 9 |
| 4.3.3 | Data area structure..... | 9 |
| 4.3.4 | Selection of the HART variables..... | 10 |
| 4.4 | CPM parameters using PROFIBUS DP..... | 11 |
| 4.5 | IOM parameters..... | 12 |
| 4.5.1 | AIM / AIMH..... | 12 |
| 4.5.2 | TIMR..... | 13 |
| 4.5.3 | TIM mV..... | 14 |
| 4.5.4 | DIM..... | 15 |
| 4.5.5 | AOM / AOMH..... | 17 |
| 4.5.6 | DOM..... | 18 |
| 4.6 | Bit coding of IOM parameters..... | 19 |
| 4.6.1 | AIM / AIMH..... | 19 |
| 4.6.2 | TIMR..... | 20 |
| 4.6.3 | TIM mV..... | 21 |
| 4.6.4 | DIM..... | 22 |
| 4.6.5 | AOM / AOMH..... | 23 |
| 4.6.6 | DOM..... | 24 |
| 5 | Release Notes..... | 25 |
| 6 | Support address..... | 25 |

Extended Parameter Set for IS1 Remote I/O System

1 Overview

This document describes the extended functions and supplements the Operating Instructions 'Description of PROFIBUS DP Interface for IS1 Field Stations' and 'Description of MODBUS RTU Interface for IS1 Field Stations'.

The Extended Parameter Set of the IS1 Remote I/O System described in this document is supported as of Version 2.00 of the GSD file for IS1

The signal assignment and scaling of the IOM have not been changed.

The descriptions below each replace the corresponding sections of the Operating Instructions mentioned above if using the Extended Parameter Set.

1.1 New features with the Extended Parameter Set

The functionality of the IS1 Remote I/O-System has been extended with the Extended Parameter Set in following points:

- Increased telegram length on PROFIBUS DP
 - 239+1 Byte Input data (112+1 Byte before)
 - 127+1 Byte Output data (80+1 Byte before)
 - 14 Byte Parameter data per IOM (5 Byte before)
 - 30 signal diagnosis messages (18 before)
- Signal parameter
 - predominant separate parameters for each single signal of IOM (previous partially module global).
- HART Variables
 - HART variables can be mapped to the cyclic data exchange of PROFIBUS DP or to MDOBUS registers and transmitted to the master (PLC/DCS).
- Status Fieldstation
 - A common alarm bit of all alarms of one IS1 fieldstation is mapped to the cyclic data on PROFIBUS DP

Extended Parameter Set for IS1 Remote I/O System

1.2 Selection of the IS1 Parameter Set

Using PROFIBUS DP, the configuration and parameterisation of IS1 field stations is done with the configurator software of the PROFIBUS DP master using GSD files.

The selection of the IS1 parameter set is made by using one of the associated GSD files.

Selection:

| PROFIBUS | IS1 Parameter set | GSD File | Documentation |
|----------|-------------------|--|--|
| DPV0 | standard | Revisions V1.xx (File name: STA_049A.gse) | additional document 'Operating Instructions PROFIBUS DP for IS1 Fieldstations' |
| | extended | Revisions V2.xx (File name: STA2049A.gse) | this document |
| DPV1 | | Revisions V3.xx (File Name: STA3049A.gse) | document 'Operating Instructions PROFIBUS DPV1 for IS1 Fieldstations' |

Using IS1 with MODBUS RTU interface or operating IS1 without automation system, configuration, parameterisation and selection of the parameter set is done via the I.S.Wizard software

1.3 Mix of IS1 field stations with different parameter sets

IS1 Field stations with Standard Parameter Set and with Extended Parameter Set can be used in any mixture on one PROFIBUS segment (on one Master).

With this it is possible, to extend existing installations with Standard Parameter Set with new IS1 field stations, which are operated with the Extended Parameter Set.

Extended Parameter Set for IS1 Remote I/O System

2 System requirements

Requirements for use of the Extended Parameter Set of the IS1 Remote I/O System:

Hardware requirements:

CPM 9440/12-01-11 (24V Z1 Stahl) as of Revision F
CPM 9440/15-01-11 (24V Z2 Stahl) as of Revision F
CPM 9440/22-01-11 (24V Z1 PNO) all Revisions
CPM 9440/22-01-21 (230V Z1 PNO) all Revisions

Software requirements:

IOM Firmware as of Revision 2.00

PROFIBUS

- GSD as of Revision V2.00
- without I.S.Wizard
 - CPM Firmware DPV0 as of Revision V01-30 or
 - CPM Firmware DPV1 as of Revision V02-30
- with I.S.Wizard V3.x.x and Service Bus
 - CPM Firmware DPV0 as of Revision V01-32 or
 - CPM Firmware DPV1 as of Revision V02-32

MODBUS:

- CPM Firmware DPV0 as of Revision V11-06
- I.S.Wizard as of Revision 3.0.0

IMPORTANT

If using older hardware or firmware versions, GSD files with Version V1.xx (less than V2.00) without Extended Parameter Set must be used with PROFIBUS DP.

Using MODBUS RTU interface and I.S.Wizard the Standard Parameter Set has to be selected.

Extended Parameter Set for IS1 Remote I/O System

3 Compatibility with existing IS1 modules

- All new modules are fully upward-compatible, i.e. each new module fully replaces the corresponding old module.
- Old and new modules can be mixed as required. As a consequence, this means that, in the case of Profibus, it is only possible to work with the Standard Parameter Set and the previous GSD (V1.xx) file if old and new modules are used in a mixed configuration. Thus, new modules behave in the same way as old modules.
- In the case of Modbus: Functions as previously.
- The extended parameter set of IS1 can be used only if GSD file and CPM and all IOMs are new (see above hardware and software requirements).
- The new GSD file (V2.xx) cannot be used for old installations with old CPM.

Function / behaviour

| param. set (GSD Rev.) | CPM | | | IOM | | Function / behaviour |
|--|-----|------------------------|----------------------------|-----|---------|--|
| | | Hardware Rev. | Software Rev. | | Version | |
| Standard Parameter Set (1.xx) | All | All | All | All | All | OK |
| Extended Parameter Set (2.xx) | Old | All | before 0x-30 | All | All | No data exchange Set parameter error CPM Message 'Version conflict GSD / CPM' in diagnostic telegram |
| | New | 9440/1.-.-. as of F | as of 0x-30 | Old | 1.xx | Data exchange OK Config effort of the IOM: Message 'IOMxx configuration not equal to module' in diagnostic telegram |
| | | 9440/2.-.-. all | DPV0: x = 1 DPV1: x = 2 | New | 2.xx | OK |

Extended Parameter Set for IS1 Remote I/O System

4 Functional description

4.1 Telegram lengths with PROFIBUS DP

| Telegram type | Previous length restriction (GSD Revision V1.xx) [Bytes] | New length restriction (as of GSD Revision V2.00) [Bytes] |
|--------------------------|--|---|
| Input data | 112 + 1 for CPM = 113 | 239 + 1 for CPM = 240 *1) |
| Output data | 80 + 1 for CPM = 81 | 127 + 1 for CPM = 128 *1) |
| DP V0 parameters | 10 + 16 IOM * 5 = 90 | 10 + 16 IOM * 14 = 234 |
| Diagnostic data | 119 Diagnostic telegram with standard + devices + identification +18 signal-specific diagnoses. | 122 Diagnostic telegram with standard + devices + identification + 30 signal-specific diagnoses. |
| DPV1 C2 channel (HART) | 75 | 75 |

4.2 Telegram lengths with MODBUS RTU

The previous limitation of the telegram length of 128 registers (2048Coils) and the addressable register area are not changed.

Using HART modules with transmission of HART variables this limits have to be observed.

The maximum possible number of I/O modules per IS1 fieldstation can be reduced.

Extended Parameter Set for IS1 Remote I/O System

4.3 Group alarm / field station status

1 byte input data (status register) and 1 byte output data (control register) are transmitted for the CPM in the cyclic range of PROFIBUS DP.

The previous descriptors in the GSD file for CPM and CPM red. have been combined to form a universal descriptor per CPM type.

The contents of the status register can be used in the AS for generation of a field station-global group alarm. In the case of applications without CPM redundancy, the function on the control register is deactivated by parameter 'CPM redundant = No' (default setting).

4.3.1 Control register CPM

If using redundant CPMs, the control register serves to control the operating states of the two redundant CPMs (see description 'Redundant coupling via PROFIBUS DP')

4.3.2 Status register CPM

The status register contains information on both possible CPMs (left and right).

In the case of operation without CPM redundancy, only the status of the left CPM must be evaluated.

The control register can be used to read back the current status of the two CPMs for checking by the AS:

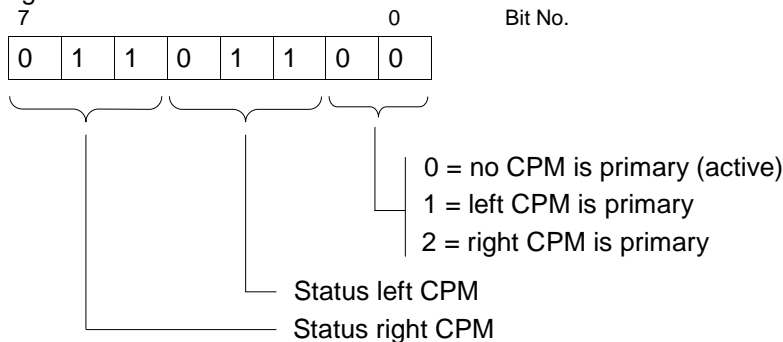

Status CPM:

| | |
|------------------|---|
| Value 1 (001) *1 | Hardware fault CPM |
| Value 2 (010) | Data exchange with AS Diagnostic data available ! --> Generate group alarm FS |
| Value 3 (011) *1 | No data exchange (after Power On) |
| Value 4 (100) *1 | Configuration or parameter error |
| Value 5 (101) *1 | Quit data exchange with AS |
| Value 6 (110) | Data exchange with AS (without diagnostic data) --> all IOMs and CPMs are non-errored |
| Value 7 (111) *1 | Inactive CPM not accessible |

*1) Important:

Value can be evaluated practically only in the case of CPM redundancy.

In the case of operation without CPM redundancy, the status register can no longer be updated in the event of bus or slave failure in the AS. Group alarm 'Diagnostic data available' can thus be practically evaluated only in the case of cyclic bus operation. Status 'Slave failure' must be scanned separately in the AS and cannot be detected by evaluation of the status register.

Extended Parameter Set for IS1 Remote I/O System

4.4 HART variables

In addition to the analogue process value, HART field devices offer the option of digitally reading up to four process variables (HART variables HV) from the transmitter.

IS1 offers the option of mapping such HART variables to the cyclic data area of PROFIBUS DP or to MODBUS registers. Optionally, no HART variables, four or eight HART variables of an IS1 HART module (AIMH, AOMH) can be transmitted in addition to the cyclic data.

This can be selected optionally when configuring a field station via the GSD file or in I.S.Wizard:

4.4.1 Module selection in GSD file / I.S. Wizard

| Module selection text | Length cyclic data [bytes] | | Number of HART variables (HVs) transmitted |
|--|----------------------------|--------|--|
| | Input | Output | |
| 9461/12-08-11 AIMH 8 2w Exi | 16 | 0 | None |
| 9461/12-08-11 AIMH 8+4HV 2w Exi | 32 | 0 | 4 HV |
| 9461/12-08-11 AIMH 8+8HV 2w Exi | 48 | 0 | 8 HV |
| 9461/12-08-21 AIMH 8 Exi | 16 | 0 | None |
| 9461/12-08-21 AIMH 8+4HV Exi | 32 | 0 | 4 HV |
| 9461/12-08-21 AIMH 8+8HV Exi | 48 | 0 | 8 HV |
| 9466/12-08-11 AOMH 8 Exi | 0 | 16 | None |
| 9466/12-08-11 AOMH 8+4HV Exi | 16 | 16 | 4 HV |
| 9466/12-08-11 AOMH 8+8HV Exi | 32 | 16 | 8 HV |

4.4.2 Data format

HART variables are transmitted as IEEE floating-point numbers (4 byte).

If a HART variable cannot be read (e.g. HART device undergoing startup, not connected, defective or HART variable not found, ...), value 7F A0 00 00 (Not a Number) is transmitted. This may be evaluated in the AS for generation of a signal status of the HART variables. Detailed status and diagnostic information of the HART field devices can be evaluated via HART Management Systems.

4.4.3 Data area structure

Example: AIMH

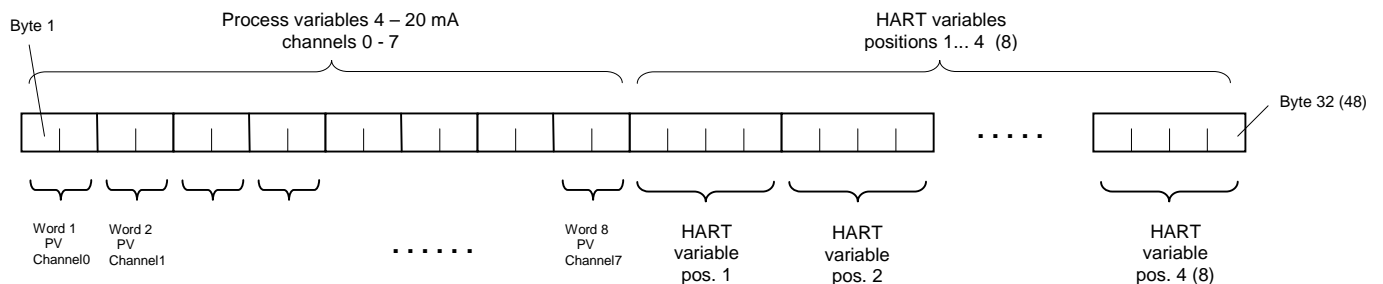

Extended Parameter Set for IS1 Remote I/O System

Example: AOMH

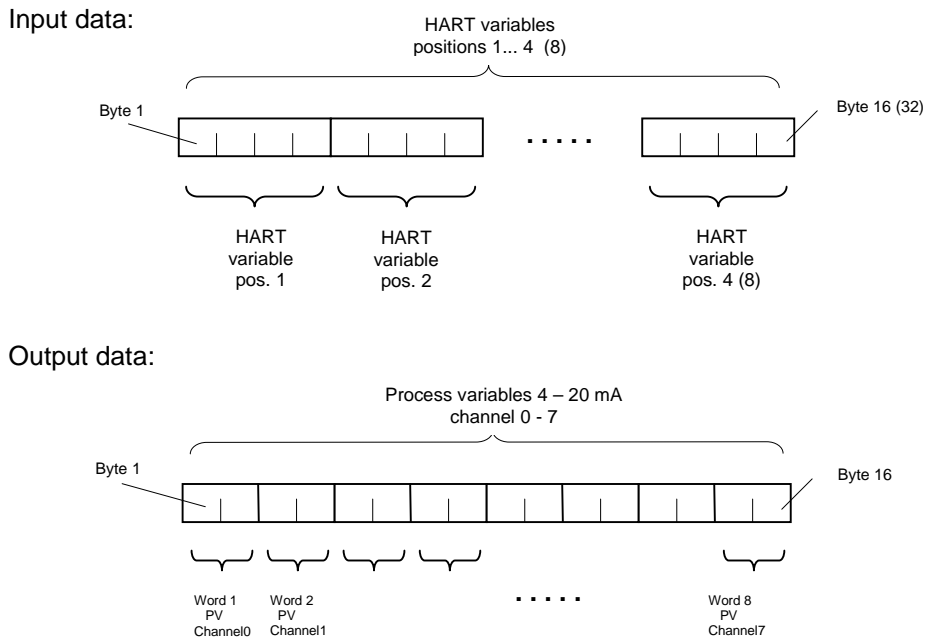

4.4.4 Selection of the HART variables

Up to 8 HART field devices can be connected to one HART module of IS1. Since each HART field device may have up to 4 variables, this means that a maximum of 32 HART variables are possible per module.

The assignment of these 32 variables to the positions in the cyclic transmission area can be selected by parameter assignment:

| Parameter name | Value range | Function |
|--------------------------------------|----------------------|---|
| Input No. HART device for pos. 1 | 0 ... 7, Not used | Selection of the channel No. (input / output No.) of the HART module to which the HART field device is connected which is to be transmitted at pos. 1. If 'Not Used' is selected, value 'Not a Number' (7F A0 00 00) is transmitted. |
| Input No. HART device for pos. 2 | 0 ... 7, Not used | Selection for pos. 2 |
| | | |
| Input No. HART device for pos. 4 (8) | 0 ... 7, Not used | Selection for pos. 4 (8) |
| No. HART variable for pos. 1 | 1 ... 4 | Selection of the variables of the HART field device which is to be transmitted at pos. 1. |
| No. HART variable for pos. 2 | 1 ... 4 | Selection for pos. 2 |
| | | |
| No. HART variable for pos. 4 (8) | 1 ... 4 | Selection for pos. 4 (8) |

Extended Parameter Set for IS1 Remote I/O System

4.5 CPM parameters using PROFIBUS DP

Byte 0: 0x00
Byte 1: 0x01
Byte 2: 0x00

} DPV1 Status bytes

Byte 3:

| | | | | | | | | | |
|---|---|---|---|---|---|---|---|---|---|
| 7 | 0 | 0 | 0 | 0 | 0 | 0 | 0 | 0 | 0 |
|---|---|---|---|---|---|---|---|---|---|

Bit no. CPM parameters

Reserved

Reserved

Reserved

Reserved

Reserved

Reserved

Reserved

| Bit 1 | Bit 0 | Address offset backup CPM PNO Red | |
|-------|-------|-----------------------------------|----|
| 0 | 0 | 128 | FR |
| 0 | 1 | 0 | SR |
| 1 | 0 | 1 | FR |
| 1 | 1 | 64 | FR |

Byte 4 – 5: Reserved (Default = 0)

Byte 6: Constant = 2 (identification for Extended Parameter Set)

Byte 7: Timeout output modules (x 100 ms) Unsigned8 (1 - 255) Default: 1

Byte 8:

| | | | | | | | | | |
|---|---|---|---|---|---|---|---|---|---|
| 7 | 0 | 0 | 0 | 0 | 0 | 0 | 0 | 1 | 0 |
|---|---|---|---|---|---|---|---|---|---|

Bit No. CPM parameters

Channel-specific diagnosis 0=Off / 1=On

Reserve

Reserve

Reserve

Reserve

IOM 9-16 on rail X4 0 = No / 1 = Yes

Line redundant AS bus 0 = No / 1 = Yes

CPM redundant 0 = No / 1 = Yes

Byte 9: Reserved (default = 0)

Extended Parameter Set for IS1 Remote I/O System

4.6 IOM parameters

4.6.1 AIM / AIMH

| Parameter | Default value | Value range / selection |
|-----------------------------------|---------------------|--|
| Diagnostic messages of the module | On | Off On |
| Input Filter | Medium | Small Medium Big (50 Hz) Big (60 Hz) |
| Signal in case of error I 0 | Alarm code | -10 % (4 mA only) 0 % 100 % Alarm code freeze (initial value 0%) freeze (initial value 100%) |
| Signal in case of error I 1 | Alarm code | |
| Signal in case of error I 2 | Alarm code | |
| Signal in case of error I 3 | Alarm code | |
| Signal in case of error I 4 | Alarm code | |
| Signal in case of error I 5 | Alarm code | |
| Signal in case of error I 6 | Alarm code | |
| Signal in case of error I 7 | Alarm code | |
| Error detection I 0 | On | Off On |
| Error detection I 1 | On | |
| Error detection I 2 | On | |
| Error detection I 3 | On | |
| Error detection I 4 | On | |
| Error detection I 5 | On | |
| Error detection I 6 | On | |
| Error detection I 7 | On | |
| Input range I 0 | 4...20 mA | 0...20 mA 4...20 mA |
| Input range I 1 | 4...20 mA | |
| Input range I 2 | 4...20 mA | |
| Input range I 3 | 4...20 mA | |
| Input range I 4 | 4...20 mA | |
| Input range I 5 | 4...20 mA | |
| Input range I 6 | 4...20 mA | |
| Input range I 7 | 4...20 mA | |
| Measurem. range ac. NAMUR I 0 | No | No Yes |
| Measurem. range ac. NAMUR I 1 | No | |
| Measurem. range ac. NAMUR I 2 | No | |
| Measurem. range ac. NAMUR I 3 | No | |
| Measurem. range ac. NAMUR I 4 | No | |
| Measurem. range ac. NAMUR I 5 | No | |
| Measurem. range ac. NAMUR I 6 | No | |
| Measurem. range ac. NAMUR I 7 | No | |
| Scan HART livelist | On | Off On |
| Input No. HART device for pos. 1 | Not used | 0...7 'Not used' |
| Input No. HART device for pos. 2 | Not used | |
| Input No. HART device for pos. 3 | Not used | |
| Input No. HART device for pos. 4 | Not used | |
| Input No. HART device for pos. 5 | Not used | |
| Input No. HART device for pos. 6 | Not used | |
| Input No. HART device for pos. 7 | Not used | |
| Input No. HART device for pos. 8 | Not used | |
| No. HART variable for pos. 1 | HART variable No. 2 | HART variable No. 1 HART variable No. 2 HART variable No. 3 HART variable No. 4 |
| No. HART variable for pos. 2 | HART variable No. 2 | |
| No. HART variable for pos. 3 | HART variable No. 2 | |
| No. HART variable for pos. 4 | HART variable No. 2 | |
| No. HART variable for pos. 5 | HART variable No. 2 | |
| No. HART variable for pos. 6 | HART variable No. 2 | |
| No. HART variable for pos. 7 | HART variable No. 2 | |
| No. HART variable for pos. 8 | HART variable No. 2 | |

Available only on HART modules (AIMH) !

Extended Parameter Set for IS1 Remote I/O System

4.6.2 TIMR

| Parameter | Default value | Value range / selection |
|-----------------------------------|---------------|---|
| Diagnostic messages of the module | On | Off On |
| Input Filter | 50 Hz | 50 Hz 60 Hz Off (not recommended) |
| Operation mode | 8 inputs | 8 inputs 2 inputs |
| Signal in case of error I 0 | Alarm code | Alarm code freeze (initialisation value 0%) |
| Signal in case of error I 1 | Alarm code | |
| Signal in case of error I 2 | Alarm code | |
| Signal in case of error I 3 | Alarm code | |
| Signal in case of error I 4 | Alarm code | |
| Signal in case of error I 5 | Alarm code | |
| Signal in case of error I 6 | Alarm code | |
| Signal in case of error I 7 | Alarm code | |
| Error detection I 0 | On | Off On |
| Error detection I 1 | On | |
| Error detection I 2 | On | |
| Error detection I 3 | On | |
| Error detection I 4 | On | |
| Error detection I 5 | On | |
| Error detection I 6 | On | |
| Error detection I 7 | On | |
| Type I 0 | Pt 100 | Pt100 Pt500 Pt1000 Ni100 Ni500 Ni1000 Resistance 10k Resistance 5k Resistance 2k5 Resistance 500R Pt100 GOST M50 GOST M100 GOST Cu53 GOST Pt46 GOST Pt50 GOST |
| Type I 1 | Pt 100 | |
| Type I 2 | Pt 100 | |
| Type I 3 | Pt 100 | |
| Type I 4 | Pt 100 | |
| Type I 5 | Pt 100 | |
| Type I 6 | Pt 100 | |
| Type I 7 | Pt 100 | |
| Connection I 0 | 4 wire | 2 wire 3 wire 4 wire |
| Connection I 1 | 4 wire | |
| Connection I 2 | 4 wire | |
| Connection I 3 | 4 wire | |
| Connection I 4 | 4 wire | |
| Connection I 5 | 4 wire | |
| Connection I 6 | 4 wire | |
| Connection I 7 | 4 wire | |

Extended Parameter Set for IS1 Remote I/O System

4.6.3 TIM mV

| Parameter | Default value | Value range / selection |
|-----------------------------------|---------------|--|
| Diagnostic messages of the module | On | Off On |
| Input Filter | 50 Hz | 50 Hz 60 Hz |
| Signal in case of error I 0 | Alarm code | Alarm code freeze (initialisation value 0%) |
| Signal in case of error I 1 | Alarm code | |
| Signal in case of error I 2 | Alarm code | |
| Signal in case of error I 3 | Alarm code | |
| Signal in case of error I 4 | Alarm code | |
| Signal in case of error I 5 | Alarm code | |
| Signal in case of error I 6 | Alarm code | |
| Signal in case of error I 7 | Alarm code | |
| Error detection I 0 | On | Off On |
| Error detection I 1 | On | |
| Error detection I 2 | On | |
| Error detection I 3 | On | |
| Error detection I 4 | On | |
| Error detection I 5 | On | |
| Error detection I 6 | On | |
| Error detection I 7 | On | |
| Type I 0 | THC Type K | 0...100 mV THC Type B THC Type E THC Type J THC Type K THC Type N THC Type R THC Type S THC Type T THC Type L THC Type U THC Type XK (L) |
| Type I 1 | THC Type K | |
| Type I 2 | THC Type K | |
| Type I 3 | THC Type K | |
| Type I 4 | THC Type K | |
| Type I 5 | THC Type K | |
| Type I 6 | THC Type K | |
| Type I 7 | THC Type K | |
| Input signal I 0 | Balanced | Balanced Unbalanced |
| Input signal I 1 | Balanced | |
| Input signal I 2 | Balanced | |
| Input signal I 3 | Balanced | |
| Input signal I 4 | Balanced | |
| Input signal I 5 | Balanced | |
| Input signal I 6 | Balanced | |
| Input signal I 7 | Balanced | |

Extended Parameter Set for IS1 Remote I/O System

4.6.4 DIM

| Parameter | Default value | Value range / selection |
|-----------------------------------|---------------|--|
| Diagnostic messages of the module | On | Off On |
| Signal in case of error I 0 | 0 | 0 1 freeze (initial value 0) freeze (initial value 1) |
| Signal in case of error I 1 | 0 | |
| Signal in case of error I 2 | 0 | |
| Signal in case of error I 3 | 0 | |
| Signal in case of error I 4 | 0 | |
| Signal in case of error I 5 | 0 | |
| Signal in case of error I 6 | 0 | |
| Signal in case of error I 7 | 0 | |
| Signal in case of error I 8 | 0 | |
| Signal in case of error I 9 | 0 | |
| Signal in case of error I 10 | 0 | |
| Signal in case of error I 11 | 0 | |
| Signal in case of error I 12 | 0 | |
| Signal in case of error I 13 | 0 | |
| Signal in case of error I 14 | 0 | |
| Signal in case of error I 15 | 0 | |
| Error detection I 0 | On | Off On |
| Error detection I 1 | On | |
| Error detection I 2 | On | |
| Error detection I 3 | On | |
| Error detection I 4 | On | |
| Error detection I 5 | On | |
| Error detection I 6 | On | |
| Error detection I 7 | On | |
| Error detection I 8 | On | |
| Error detection I 9 | On | |
| Error detection I 10 | On | |
| Error detection I 11 | On | |
| Error detection I 12 | On | |
| Error detection I 13 | On | |
| Error detection I 14 | On | |
| Error detection I 15 | On | |
| Invert I 0 | No | No Yes |
| Invert I 1 | No | |
| Invert I 2 | No | |
| Invert I 3 | No | |
| Invert I 4 | No | |
| Invert I 5 | No | |
| Invert I 6 | No | |
| Invert I 7 | No | |
| Invert I 8 | No | |
| Invert I 9 | No | |
| Invert I 10 | No | |
| Invert I 11 | No | |
| Invert I 12 | No | |
| Invert I 13 | No | |
| Invert I 14 | No | |
| Invert I 15 | No | |

Parameters not present on DIM 24 V ! (9471/...)

Extended Parameter Set for IS1 Remote I/O System

| | | |
|-----------------------|--------------------|---|
| Pulse extension I 0 | 0 Sec. | 0 s 0.6 s 1.2 s 2.4 s |
| Pulse extension I 1 | 0 Sec. | |
| Pulse extension I 2 | 0 Sec. | |
| Pulse extension I 3 | 0 Sec. | |
| Pulse extension I 4 | 0 Sec. | |
| Pulse extension I 5 | 0 Sec. | |
| Pulse extension I 6 | 0 Sec. | |
| Pulse extension I 7 | 0 Sec. | |
| Pulse extension I 8 | 0 Sec. | |
| Pulse extension I 9 | 0 Sec. | |
| Pulse extension I 10 | 0 Sec. | |
| Pulse extension I 11 | 0 Sec. | |
| Pulse extension I 12 | 0 Sec. | |
| Pulse extension I 13 | 0 Sec. | |
| Pulse extension I 14 | 0 Sec. | |
| Pulse extension II 15 | 0 Sec. | |
| Operation mode I 14 | Freq. 0-1 kHz / DI | Counter Freq. 0-1 kHz / DI Freq. 0-20 kHz gate 50 ms / DI Freq. 0-20 kHz gate 200 ms / DI Freq. 0-20 kHz gate 1 s / DI |
| Counter event I 14 | Positive edge | Positive edge Negative edge |
| Operation mode I 15 | Freq. 0-1 kHz / DI | s. a. |
| Counter event I 15 | Positive edge | s. a. |

Parameters available only in the case of operating mode DIM16 + CF!

Extended Parameter Set for IS1 Remote I/O System

4.6.5 AOM / AOMH

| Parameter | Default value | Value range / selection |
|-----------------------------------|---------------------|---|
| Diagnostic messages of the module | On | Off On |
| Signal in case of error O 0 | 0 % | -10 % (4 mA only) 0 % 100 % 110 % freeze |
| Signal in case of error O 1 | 0 % | |
| Signal in case of error O 2 | 0 % | |
| Signal in case of error O 3 | 0 % | |
| Signal in case of error O 4 | 0 % | |
| Signal in case of error O 5 | 0 % | |
| Signal in case of error O 6 | 0 % | |
| Signal in case of error O 7 | 0 % | |
| Error detection O 0 | On | Off On |
| Error detection O 1 | On | |
| Error detection O 2 | On | |
| Error detection O 3 | On | |
| Error detection O 4 | On | |
| Error detection O 5 | On | |
| Error detection O 6 | On | |
| Error detection O 7 | On | |
| Output range O 0 | 4...20 mA | 0...20 mA 4...20 mA |
| Output range O 1 | 4...20 mA | |
| Output range O 2 | 4...20 mA | |
| Output range O 3 | 4...20 mA | |
| Output range O 4 | 4...20 mA | |
| Output range O 5 | 4...20 mA | |
| Output range O 6 | 4...20 mA | |
| Output range O 7 | 4...20 mA | |
| Scan HART livelist | On | Off On |
| Output No. HART device for pos. 1 | Not used | 0...7 Not used |
| Output No. HART device for pos. 2 | Not used | |
| Output No. HART device for pos. 3 | Not used | |
| Output No. HART device for pos. 4 | Not used | |
| Output No. HART device for pos. 5 | Not used | |
| Output No. HART device for pos. 6 | Not used | |
| Output No. HART device for pos. 7 | Not used | |
| Output No. HART device for pos. 8 | Not used | |
| No. HART variable for pos. 1 | HART variable No. 2 | HART variable No. 1 HART variable No. 2 HART variable No. 3 HART variable No. 4 |
| No. HART variable for pos. 2 | HART variable No. 2 | |
| No. HART variable for pos. 3 | HART variable No. 2 | |
| No. HART variable for pos. 4 | HART variable No. 2 | |
| No. HART variable for pos. 5 | HART variable No. 2 | |
| No. HART variable for pos. 6 | HART variable No. 2 | |
| No. HART variable for pos. 7 | HART variable No. 2 | |
| No. HART variable for pos. 8 | HART variable No. 2 | |

Available only on HART modules (AOMH) !

Extended Parameter Set for IS1 Remote I/O System

4.6.6 DOM

| Parameter | Default value | Value range / selection | Parameter available | | |
|-----------------------------------|------------------|---|---------------------|------|------|
| | | | DOM | DOMR | DOMV |
| Diagnostic messages of the module | On | Off On | ✓ | ✓ | ✓ |
| Signal in case of error O 0 | 0 | 0 1 Freeze | ✓ | ✓ | ✓ |
| Signal in case of error O 1 | 0 | | | | |
| Signal in case of error O 2 | 0 | | | | |
| Signal in case of error O 3 | 0 | | | | |
| Signal in case of error O 4 | 0 | | | | |
| Signal in case of error O 5 | 0 | | | | |
| Signal in case of error O 6 | 0 | | | | |
| Signal in case of error O 7 | 0 | | | | |
| Error detection O 0 | On | Off On without test current On | ✓ | - | - |
| Error detection O 1 | On | | | | |
| Error detection O 2 | On | | | | |
| Error detection O 3 | On | | | | |
| Error detection O 4 | On | | | | |
| Error detection O 5 | On | | | | |
| Error detection O 6 | On | | | | |
| Error detection O 7 | On | | | | |
| Output 0 and 1 parallel | Outputs separate | Outputs separate Outputs parallel | ✓ | ✓ | - |
| Output 2 and 3 parallel | Outputs separate | | | | |
| Output 4 and 5 parallel | Outputs separate | | | | |
| Output 6 and 7 parallel | Outputs separate | | | | |

Extended Parameter Set for IS1 Remote I/O System

4.7 Bit coding of IOM parameters

4.7.1 AIM / AIMH

| Byte | Hex | 7 | 6 | 5 | 4 | 3 | 2 | 1 | 0 | Parameter | Value | |
|------|-----|---|---|---|---|---|---|---|---|-----------------------------------|--|---|
| 0 | 13 | | | | | | | 1 | | Diagnostic messages of the module | 0 = Off 1 = On | |
| | | | | | | 0 | 0 | 1 | | Input Filter | 0 = small 1 = medium 2 = big (50 Hz) 3 = big (60 Hz) | |
| | | | | 1 | | | | | | Scan HART Livelist | 0 = Off 1 = On | |
| | | 0 | | 0 | | 0 | | | | Not used | | |
| 1 | BB | | | | | | | 0 | 1 | 1 | Signal in case of error I 0 | 0 = -10 % (4 mA) only 1 = 0 % 2 = 100 % 3 = Alarm Code 6 = freeze (initial value 0%) 7 = freeze (initial value 100%) |
| | | | | 1 | | | | | | Error detection I 0 | 0 = Off 1 = On | |
| 2 | BB | | | | | | | 0 | 1 | 1 | Signal in case of error I 1 | s. a. |
| | | | | 1 | | | | | | Error detection I 1 | | |
| 3 | BB | | | | | | | 0 | 1 | 1 | Signal in case of error I 2 | |
| | | | | 1 | | | | | | Error detection I 2 | | |
| 4 | BB | | | | | | | 0 | 1 | 1 | Signal in case of error I 3 | |
| | | | | 1 | | | | | | Error detection I 3 | | |
| 5 | FF | | | | | | | 0 | 1 | 1 | Signal in case of error I 4 | |
| | | | | 1 | | | | | | Error detection I 4 | | |
| 6 | 00 | | | | | | | 0 | 1 | 1 | Signal in case of error I 5 | |
| | | | | 1 | | | | | | Error detection I 5 | | |
| 7 | 88 | | | | | | | 0 | 1 | 1 | Signal in case of error I 6 | |
| | | | | 1 | | | | | | Error detection I 6 | | |
| 8 | 88 | | | | | | | 0 | 1 | 1 | Signal in case of error I 7 | |
| | | | | 1 | | | | | | Error detection I 7 | | |
| 9 | 55 | | | | | | | 1 | | | Input range I 0 | 0 = 0...20 mA 1 = 4...20 mA |
| | | | | | | | | 1 | | | Input range I 1 | |
| | | | | | | | | 1 | | | Input range I 2 | |
| | | | | | | | | 1 | | | Input range I 3 | |
| | | | | | | | | 1 | | | Input range I 4 | |
| | | | | | | | | 1 | | | Input range I 5 | |
| | | | | | | | | 1 | | | Input range I 6 | |
| | | | | | | | | 1 | | | Input range I 7 | |
| 10 | 00 | | | | | | | 0 | | | Measur. range ac. NAMUR I 0 | 0 = No 1 = Yes |
| | | | | | | | | 0 | | | Measur. range ac. NAMUR I 1 | |
| | | | | | | | | 0 | | | Measur. range ac. NAMUR I 2 | |
| | | | | | | | | 0 | | | Measur. range ac. NAMUR I 3 | |
| | | | | | | | | 0 | | | Measur. range ac. NAMUR I 4 | |
| | | | | | | | | 0 | | | Measur. range ac. NAMUR I 5 | |
| | | | | | | | | 0 | | | Measur. range ac. NAMUR I 6 | |
| | | | | | | | | 0 | | | Measur. range ac. NAMUR I 7 | |
| 11 | 88 | 1 | | 0 | | 0 | | 0 | | Input No. HART device for pos. 1 | 0...7 8 = 'not used' (9 – 15 Reserved) | |
| | | 1 | | 0 | | 0 | | 0 | | Input No. HART device for pos. 2 | | |
| 12 | 55 | 1 | | 0 | | 0 | | 0 | | Input No. HART device for pos. 3 | 0 = HART Variable No. 1 1 = HART Variable No. 2 *1) 2 = HART Variable No. 3 3 = HART Variable No. 4 | |
| | | 1 | | 0 | | 0 | | 0 | | Input No. HART device for pos. 4 | | |
| 13 | 00 | 1 | | 0 | | 0 | | 0 | | Input No. HART device for pos. 5 | 0...7 8 = 'Nicht verwendet' (9 – 15 Reserved) | |
| | | 1 | | 0 | | 0 | | 0 | | Input No. HART device for pos. 6 | | |
| 14 | 88 | 1 | | 0 | | 0 | | 0 | | Input No. HART device for pos. 7 | 0 = HART Variable No. 1 1 = HART Variable No. 2 *1) 2 = HART Variable No. 3 3 = HART Variable No. 4 | |
| | | 1 | | 0 | | 0 | | 0 | | Input No. HART device for pos. 8 | | |
| 15 | 55 | 1 | | 0 | | 0 | | 0 | | No. HART variable for pos. 5 | 0 = HART Variable No. 1 1 = HART Variable No. 2 *1) 2 = HART Variable No. 3 3 = HART Variable No. 4 | |
| | | 1 | | 0 | | 0 | | 0 | | No. HART variable for pos. 6 | | |
| 16 | 88 | 1 | | 0 | | 0 | | 0 | | No. HART variable for pos. 7 | 0 = HART Variable No. 1 1 = HART Variable No. 2 *1) 2 = HART Variable No. 3 3 = HART Variable No. 4 | |
| | | 1 | | 0 | | 0 | | 0 | | No. HART variable for pos. 8 | | |
| 17 | 00 | | | | | | | | | Not used | | |

Extended Parameter Set for IS1 Remote I/O System

4.7.2 TIMR

| Byte | Hex | 7 | 6 | 5 | 4 | 3 | 2 | 1 | 0 | Parameter | Value |
|----------|-----|---------|---|---|---------|---|---------|---|---|-----------------------------------|--|
| 0 | 01 | | | | | | | | 1 | Diagnostic messages of the module | 0 = Off 1 = On |
| | | | | | | | 0 0 | | | Input Filter | 0 = 50 Hz 1 = 60 Hz 2 = Off (not recommended) |
| | | | | | 0 | | | | | not used | |
| | | 0 0 0 | | | 0 | | | | | Operation mode | 0 = 8 inputs 1 = 2 inputs |
| 1 | BB | | | | | | 0 1 1 | | | Signal in case of error I 0 | 3 = Alarm Code 6 = freeze (Init. value 0%) 0 = Off 1 = On |
| | | | | | 1 | | | | | Error detection I 0 | |
| 2 | BB | | | | | | 0 1 1 | | | Signal in case of error I 1 | |
| | | 1 | | | 0 1 1 | | | | | Error detection I 1 | |
| 3 | BB | | | | | | 0 1 1 | | | Signal in case of error I 2 | |
| | | 1 | | | 0 1 1 | | | | | Error detection I 2 | |
| 4 | BB | | | | | | 0 1 1 | | | Signal in case of error I 3 | |
| | | 1 | | | 0 1 1 | | | | | Error detection I 3 | |
| 5 | AA | | | | | | 1 0 | | | Signal in case of error I 4 | 0 = 2 wire 1 = 3 wire 2 = 4 wire |
| | | 1 0 | | | 1 0 | | | | | Error detection I 4 | |
| 6 | AA | | | | | | 1 0 | | | Signal in case of error I 5 | |
| | | 1 0 | | | 1 0 | | | | | Error detection I 5 | |
| 7 | 00 | | | | | | 0 0 0 0 | | | Signal in case of error I 6 | 0 = Pt100 1 = Pt500 2 = Pt1000 3 = Ni100 4 = Ni500 5 = Ni1000 6 = Resistance 10k 7 = Resistance 5k 8 = Resistance 2k5 9 = Resistance 500R 10 = Pt100 GOST 11 = M50 GOST 12 = M100 GOST 13 = Cu53 GOST 14 = Pt46 GOST 15 = Pt50 GOST |
| | | 0 0 0 0 | | | 0 0 0 0 | | | | | Error detection I 6 | |
| 8 | 00 | | | | | | 0 0 0 0 | | | Signal in case of error I 7 | } from Fw. V02-04 |
| | | 0 0 0 0 | | | 0 0 0 0 | | | | | Error detection I 7 | |
| 9 | 00 | | | | | | 0 0 0 0 | | | Connection I 0 | } from Fw. V02-05 |
| | | 0 0 0 0 | | | 0 0 0 0 | | | | | Connection I 1 | |
| 10 | 00 | | | | | | 0 0 0 0 | | | Connection I 2 | |
| | | 0 0 0 0 | | | 0 0 0 0 | | | | | Connection I 3 | |
| 11 ..13 | 00 | | | | | | 0 0 0 0 | | | Connection I 4 | |
| | | 0 0 0 0 | | | 0 0 0 0 | | | | | Connection I 5 | |
| 11 ..13 | 00 | | | | | | 0 0 0 0 | | | Connection I 6 | |
| | | 0 0 0 0 | | | 0 0 0 0 | | | | | Connection I 7 | |
| not used | | | | | | | | | | | |

Extended Parameter Set for IS1 Remote I/O System

4.7.3 TIM mV

| Byte | Hex | 7 | 6 | 5 | 4 | 3 | 2 | 1 | 0 | Parameter | Value | | |
|--------|-----|---|---|---|---|---|---|---|---|-----------|-----------------------------------|---|--|
| 0 | 01 | | | | | | | | | 1 | Diagnostic messages of the module | 0 = Off 1 = On | |
| | | | | | | | | | | 0 | Input Filter | 0 = 50 Hz 1 = 60 Hz | |
| | | 0 | 0 | 0 | 0 | 0 | 0 | | | Not used | | | |
| 1 | BB | | | | | | | | | 0 1 1 | Signal in case of error I 0 | 3 = Alarm Code 6 = freeze (Init. value 0%) 0 = Off 1 = On | |
| | | | | | | | | | | 1 | Error detection I 0 | | |
| | | 0 | 1 | 1 | | | | | | | | Signal in case of error I 1 | |
| | | 1 | | | | | | | | | | Error detection I 1 | |
| 2 | BB | | | | | | | | | 0 1 1 | Signal in case of error I 2 | 0 = Balanced 1 = Unbalanced | |
| | | | | | | | | | | 1 | Error detection I 2 | | |
| | | 0 | 1 | 1 | | | | | | | | Signal in case of error I 3 | |
| | | 1 | | | | | | | | | | Error detection I 3 | |
| 3 | BB | | | | | | | | | 0 1 1 | Signal in case of error I 4 | 0 = Balanced 1 = Unbalanced | |
| | | | | | | | | | | 1 | Error detection I 4 | | |
| | | 0 | 1 | 1 | | | | | | | | Signal in case of error I 5 | |
| | | 1 | | | | | | | | | | Error detection I 5 | |
| 4 | BB | | | | | | | | | 0 1 1 | Signal in case of error I 6 | 0 = Balanced 1 = Unbalanced | |
| | | | | | | | | | | 1 | Error detection I 6 | | |
| | | 0 | 1 | 1 | | | | | | | | Signal in case of error I 7 | |
| | | 1 | | | | | | | | | | Error detection I 7 | |
| 5 | 00 | | | | | | | | | 0 | Input signal I 0 | 0 = Balanced 1 = Unbalanced | |
| | | | | | | | | | | 0 | Input signal I 1 | | |
| | | | | | | | | | | 0 | Input signal I 2 | | |
| | | | | | | | | | | 0 | Input signal I 3 | | |
| | | | | | | | | | | 0 | Input signal I 4 | | |
| | | | | | | | | | | 0 | Input signal I 5 | | |
| | | | | | | | | | | 0 | Input signal I 6 | | |
| | | | | | | | | | | 0 | Input signal I 7 | | |
| 6 | 44 | | | | | | | | | 0 1 0 0 | Type I 0 | 0 = 0...100 mV 1 = THC Type B 2 = THC Type E 3 = THC Type J 4 = THC Type K 5 = THC Type N 6 = THC Type R 7 = THC Type S 8 = THC Type T 9 = THC Type L 10 = THC Type U 11 = THC Type XK (L) | |
| | | 0 | 1 | 0 | 0 | | | | | | | | |
| 7 | 44 | | | | | | | | | 0 1 0 0 | Type I 2 | (12...15 = reserved) | |
| | | 0 | 1 | 0 | 0 | | | | | | | | |
| 8 | 44 | | | | | | | | | 0 1 0 0 | Type I 4 | (12...15 = reserved) | |
| | | 0 | 1 | 0 | 0 | | | | | | | | |
| 9 | 44 | | | | | | | | | 0 1 0 0 | Type I 6 | (12...15 = reserved) | |
| | | 0 | 1 | 0 | 0 | | | | | | | | |
| 10..13 | 00 | | | | | | | | | | | Not used | |

Extended Parameter Set for IS1 Remote I/O System

4.7.4 DIM

| Byte | Hex | 7 | 6 | 5 | 4 | 3 | 2 | 1 | 0 | Parameter | Value | |
|------|-----|---|---|---|---|---|---|---|---------------------|-----------------------------------|--|-------|
| 0 | 01 | | | | | | | | 1 | Diagnostic messages of the module | 0 = Off 1 = On | |
| | | 0 | 0 | 0 | 0 | 0 | 0 | 0 | | Not used | | |
| 1 | FF | | | | | | | | 1 | Error detection I 0 | 0 = Off 1 = On | |
| | | | | | | | | 1 | Error detection I 1 | | | |
| | | | | | | | 1 | | Error detection I 2 | | | |
| | | | | | | 1 | | | Error detection I 3 | | | |
| | | | | | 1 | | | | Error detection I 4 | | | |
| | | | | 1 | | | | | Error detection I 5 | | | |
| | | 1 | | | | | | | Error detection I 6 | | | |
| | | 1 | | | | | | | Error detection I 7 | | | |
| 2 | FF | | | | | | | | 1 | Error detection I 8 | | |
| | | 1 | 1 | 1 | 1 | 1 | 1 | 1 | 1 | ... | | |
| | | | | | | | | | | Error detection I 15 | | |
| 3 | 00 | | | | | 0 | 0 | | | Signal in case of error I 0 | 0 = 0 1 = 1 2 = freeze (initial value 0) 3 = freeze (initial value 1) | |
| | | | | | 0 | 0 | | | | Signal in case of error I 1 | | |
| | | | 0 | 0 | | | | | | Signal in case of error I 2 | | |
| | | | 0 | 0 | | | | | | Signal in case of error I 3 | | |
| 4 | 00 | | | 0 | 0 | 0 | 0 | | | Signal in case of error I 4 | | |
| | | 0 | 0 | | | | | | | ... | | |
| | | | | | | | | | | Signal in case of error I 7 | | |
| 5 | 00 | | | 0 | 0 | 0 | 0 | | | Signal in case of error I 8 | | |
| | | 0 | 0 | | | | | | | ... | | |
| | | | | | | | | | | Signal in case of error I 11 | | |
| 6 | 00 | | | 0 | 0 | 0 | 0 | | | Signal in case of error I 12 | | |
| | | 0 | 0 | | | | | | | ... | | |
| | | | | | | | | | | Signal in case of error I 15 | | |
| 7 | 00 | | | | | 0 | 0 | | | Pulse extension I 0 | 0 = 0 s 1 = 0,6 s 2 = 1,2 s 3 = 2,4 s | |
| | | | | | | 0 | 0 | | | Pulse extension I 1 | | |
| | | | 0 | 0 | | | | | | Pulse extension I 2 | | |
| | | | 0 | 0 | | | | | | Pulse extension I 3 | | |
| 8 | 00 | | | 0 | 0 | 0 | 0 | | | Pulse extension I 4 | | |
| | | 0 | 0 | | | | | | | ... | | |
| | | | | | | | | | | Pulse extension I 7 | | |
| 9 | 00 | | | 0 | 0 | 0 | 0 | | | Pulse extension I 8 | | |
| | | 0 | 0 | | | | | | | ... | | |
| | | | | | | | | | | Pulse extension I 11 | | |
| 10 | 00 | | | 0 | 0 | 0 | 0 | | | Pulse extension I 12 | | |
| | | 0 | 0 | | | | | | | ... | | |
| | | | | | | | | | | Pulse extension I 15 | | |
| 11 | 00 | | | | | | | | 0 | Invert I 0 | 0 = no 1 = yes | |
| | | | | | | | | 0 | | Invert I 1 | | |
| | | | | | | | 0 | | | Invert I 2 | | |
| | | | | | 0 | | | | | Invert I 3 | | |
| | | | | 0 | | | | | | Invert I 4 | | |
| | | | 0 | | | | | | | Invert I 5 | | |
| | | 0 | | | | | | | | Invert I 6 | | |
| | | 0 | | | | | | | | Invert I 7 | | |
| 12 | 00 | | 0 | 0 | 0 | 0 | 0 | 0 | | Invert I 8 | | |
| | | 0 | | | | | | | | ... | | |
| | | | | | | | | | | Invert I 15 | | |
| 13 | 11 | | | | | | 0 | 0 | 1 | Operation mode I 14 | 0 = counter 1 = Freq. 0-1 kHz / DI 2 = Freq. 0-20 kHz gate 50 ms / DI 3 = Freq. 0-20 kHz gate 200 ms / DI 4 = Freq. 0-20 kHz gate 1 s / DI | |
| | | | | | | 0 | | | | Counter event I 14 | 0 = Positive edge 1 = Negative edge | |
| | | | 0 | 0 | 1 | | | | | | Operation mode I 15 | s. a. |
| | | 0 | | | | | | | | | Counter event I 15 | |

Extended Parameter Set for IS1 Remote I/O System

4.7.5 AOM / AOMH

| Byte | Hex | 7 | 6 | 5 | 4 | 3 | 2 | 1 | 0 | Parameter | Value | | |
|----------|-----|---|---|---|---|---|---|---|---|-----------------------------------|--|-----------------------------------|-------------------------|
| 0 | 11 | | | | | | | 1 | | Diagnostic messages of the module | 0 = Off 1 = On | | |
| | | | | | | | | 0 | 0 | 0 | not used | | |
| | | | | | | | | 1 | | | Scan HART Livelist | 0 = Aus 1 = Ein | |
| 1 | 99 | | | | | | | | | Signal in case of error O 0 | 0 = -10 % (4 mA only) 1 = 0 % 2 = 100 % 3 = 110 % 7 = freeze | | |
| | | | | | | | | 1 | | | Error detection O 0 | 0 = Off 1 = On | |
| | | | | | | | | 0 | 0 | 1 | Signal in case of error O 1 | | |
| 2 | 99 | | | | | | | | | Error detection O 1 | | | |
| | | | | | | | | 1 | | | Signal in case of error O 2 | | |
| | | | | | | | | 0 | 0 | 1 | Error detection O 2 | | |
| 3 | 99 | | | | | | | | | Signal in case of error O 3 | | | |
| | | | | | | | | 1 | | | Error detection O 3 | s. a. | |
| | | | | | | | | 0 | 0 | 1 | Signal in case of error O 4 | | |
| 4 | 99 | | | | | | | | | Error detection O 4 | | | |
| | | | | | | | | 1 | | | Signal in case of error O 5 | | |
| | | | | | | | | 0 | 0 | 1 | Error detection O 5 | | |
| 5 | FF | | | | | | | | | Signal in case of error O 6 | | | |
| | | | | | | | | 1 | | | Error detection O 6 | | |
| | | | | | | | | 0 | 0 | 1 | Signal in case of error O 7 | | |
| 6 | 88 | | | | | | | | | Error detection O 7 | | | |
| | | | | | | | | 1 | | | Output range O 0 | 0 = 0...20 mA 1 = 4...20 mA | |
| | | | | | | | | 0 | 0 | 1 | Output range O 1 | | |
| 7 | 88 | | | | | | | | | Output range O 2 | | | |
| | | | | | | | | 1 | | | Output range O 3 | | |
| | | | | | | | | 0 | 0 | 1 | Output range O 4 | | |
| 8 | 55 | | | | | | | | | Output range O 5 | | | |
| | | | | | | | | 1 | | | Output range O 6 | | |
| | | | | | | | | 0 | 0 | 1 | Output range O 7 | | |
| 9 | 88 | | | | | | | | | Output No. HART device for pos. 1 | 0...7 | | |
| | | | | | | | | 1 | 0 | 0 | 0 | Output No. HART device for pos. 2 | 8 = 'Not used' |
| | | | | | | | | 1 | 0 | 0 | 0 | Output No. HART device for pos. 3 | (9 – 15 Reserved) |
| 10 | 88 | | | | | | | | | Output No. HART device for pos. 4 | | | |
| | | | | | | | | 0 | 1 | | | No. HART variable for pos. 1 | 0 = HART Variable No. 1 |
| | | | | | | | | 0 | 1 | | | No. HART variable for pos. 2 | 1 = HART Variable No. 2 |
| 11 | 55 | | | | | | | | | No. HART variable for pos. 3 | 2 = HART Variable No. 3 | | |
| | | | | | | | | 0 | 1 | | | No. HART variable for pos. 4 | 3 = HART Variable No. 4 |
| | | | | | | | | 1 | 0 | 0 | 0 | Output No. HART device for pos. 5 | 0...7 |
| 12..13 | 00 | | | | | | | | | Output No. HART device for pos. 6 | 8 = 'Not used' | | |
| | | | | | | | | 1 | 0 | 0 | 0 | Output No. HART device for pos. 7 | (9 – 15 Reserved) |
| | | | | | | | | 1 | 0 | 0 | 0 | Output No. HART device for pos. 8 | |
| | | | | | | | | 0 | 1 | | | No. HART variable for pos. 5 | 0 = HART Variable No. 1 |
| | | | | | | | | 0 | 1 | | | No. HART variable for pos. 6 | 1 = HART Variable No. 2 |
| | | | | | | | | 0 | 1 | | | No. HART variable for pos. 7 | 2 = HART Variable No. 3 |
| | | | | | | | | 0 | 1 | | | No. HART variable for pos. 8 | 3 = HART Variable No. 4 |
| Not used | | | | | | | | | | | | | |

Extended Parameter Set for IS1 Remote I/O System

4.7.6 DOM

| Byte | Hex | 7 | 6 | 5 | 4 | 3 | 2 | 1 | 0 | Parameter | Value |
|--------|-----|---|---|---|---|---|---|---|---|-----------------------------------|--|
| 0 | 01 | | | | | | | | 1 | Diagnostic messages of the module | 0 = Off 1 = On |
| | | 0 | 0 | 0 | 0 | 0 | 0 | 0 | | Not used | |
| 1 | 00 | | | | | | | | 0 | Signal in case of error O 0 | 0 = 0 1 = 1 2 = Freeze |
| | | | | | | | | | | Not used | |
| 2 | 00 | | | | | | | | 0 | Signal in case of error O 1 | |
| | | | | | | | | | | Not used | |
| 3 | 00 | | | | | | | | 0 | Signal in case of error O 2 | |
| | | | | | | | | | | Not used | |
| 4 | 00 | | | | | | | | 0 | Signal in case of error O 3 | |
| | | | | | | | | | | Not used | |
| 5 | 00 | | | | | | | | 0 | Signal in case of error O 4 | |
| | | | | | | | | | | Not used | |
| 6 | 00 | | | | | | | | 0 | Signal in case of error O 5 | |
| | | | | | | | | | | Not used | |
| 7 | 00 | | | | | | | | 0 | Signal in case of error O 6 | |
| | | | | | | | | | | Not used | |
| 8 | 00 | | | | | | | | 0 | Signal in case of error O 7 | |
| | | | | | | | | | | Not used | |
| 9 | AA | | | | | | | | 1 | Error detection O 0 | 0 = Off 1 = On without test current 2 = On |
| | | | | | | | | | 0 | Error detection O 1 | |
| 10 | AA | | | | | | | | 1 | Error detection O 2 | |
| | | | | | | | | | 0 | Error detection O 3 | |
| 11 | AA | | | | | | | | 1 | Error detection O 4 | |
| | | | | | | | | | 0 | Error detection O 5 | |
| 12 | AA | | | | | | | | 1 | Error detection O 6 | |
| | | | | | | | | | 0 | Error detection O 7 | |
| 13 | AA | | | | | | | | 1 | Error detection O 0 | |
| | | | | | | | | | 0 | Error detection O 1 | |
| 14 | 00 | | | | | | | | 0 | Output 0 and 1 parallel | 0 = Outputs separate 1 = Outputs parallel |
| | | | | | | | | | 0 | Output 2 and 3 parallel | |
| 15 | 00 | | | | | | | | 0 | Output 4 and 5 parallel | |
| | | | | | | | | | 0 | Output 6 and 7 parallel | |
| 16 | 00 | | | | | | | | 0 | Not used | |
| | | | | | | | | | | Not used | |
| 17..20 | 00 | | | | | | | | | Not used | |

Extended Parameter Set for IS1 Remote I/O System

5 Release Notes

| Date/Rev. | Description / change / extension |
|-----------|---|
| 11.02.03 | First version with Extended Parameter Set for IS1 (GSD Rev. 2.00) |
| 27.03.03 | Bugfix: Data length changed in configuration data of module (GSD Rev. 2.01) 9466/12-08-11 AOMH 8 + 8HV Exi If this module descriptor is used with DSF/GSD 2.00, the CPM issues a deny error with configuration error and does not revert to data exchange status. |
| 16.04.04 | Description extended: <ul style="list-style-type: none"> • MODBUS • Bit coding of parameters. |
| 29.06.04 | Parameter 'Scan HART Livelist' added |
| 02.05.07 | New parameter for 9480: (9480 module FW-Revision from 02-04 required) <ul style="list-style-type: none"> • PT100 GOST • M50 GOST • M100 GOST |
| 1.25 | <ul style="list-style-type: none"> • PNO Slave Redundancy: <ul style="list-style-type: none"> - CPM parameter added: 'Address Offset backup CPM PNO Red' • Module added: DOMV 9478/28-08-51 • 9480 TIMR Parameters added for CU53 GOST, Pt46 GOST, Pt50 GOST |

6 Support address

R. Stahl Schaltgeräte GmbH

Center of Competence Instrumentation Systems

eMail: support.instrumentation@stahl.de

Support information: <http://www.stahl.de>

Service hotline IS1: +49 (7942) 943-4123

Telefax : +49 (7942) 943-40 4123