

Description of

MODBUS TCP Interface

for

IS1 field stations



MODBUS TCP interface description

Content:

Historical development of the field bus technology at R. STAHL.....	3
1 System overview	5
2 Commissioning.....	7
2.1 Overview	7
2.2 System requirements	8
2.3 Engineering limits.....	8
2.4 Addressing the IS1 field station.....	8
2.4.1 BOOTP (Bootstrap Protocol)	9
2.4.2 Address Conflict Detection (ACD).....	9
2.5 Port allocations for MODBUS TCP	10
2.6 System start-up behaviour	10
2.7 Overview MODBUS Functions.....	11
2.7.1 MODBUS-FUNCTION 08 - Diagnostics	12
2.7.2 MODBUS-FUNCTION 43 (0x2B) - Read Device Identification	12
2.8 MODBUS error codes	13
2.9 MODBUS TCP Multi Client operation	14
3 Data traffic	15
3.1 Signal marshalling.....	15
3.1.1 Register allocation of I/O data:.....	16
3.1.2 Extract from the allocation table	18
3.1.3 Rules for message processing:.....	19
3.2 Status register CPU.....	20
3.3 Control register.....	21
3.4 Module alarms.....	22
3.5 Signal status.....	23
3.6 CPU Redundancy.....	24
3.6.1 Non redundant Ethernet Network	24
3.6.2 Redundant Ethernet Networks.....	25
3.6.3 Ethernet IP Addresses:.....	26
3.6.4 Parameterisation:.....	26
3.6.5 Selection of 'CPU start condition'	26
3.6.6 Download of Configuration and Parameter data to redundant CPUs.....	27
3.6.7 HART	27
3.6.8 Diagnosis using IS1 DTMs.....	28
3.6.9 WEB Server der IS1 CPUs	28
3.6.10 Process data of CPUs during redundancy switch over	28
3.6.11 State of redundant CPU.....	29
3.6.12 Prepared / deactivated redundancy.....	31
3.7 Setting parameters for the IS1 field station and the I/O modules	31
3.8 Extended parameter set for IS1	32
3.8.1 CPU parameters	32
3.8.2 I/O module parameters	33
3.8.2.1 AIM / AIMH	33
3.8.2.2 TIMR.....	33
3.8.2.3 TIM mV.....	35
3.8.2.4 DIM.....	36
3.8.2.5 AOM / AOMH	38
3.8.2.6 DOM	39
3.9 Data word structure of the I/O modules	40
3.9.1 Analogue modules	40
3.9.2 DIM, DIM+CF (9470/.. 9471/..)	43
3.9.3 DOM (9475/.., 9476/.., 9477/..).....	47

MODBUS TCP interface description

3.10	Signal behaviour in case of errors.....	48
3.10.1	Behaviour of the input signals in case of errors.....	48
3.10.2	Behaviour of the output signals in case of errors.....	49
3.11	HART variables	50
3.11.1	Module selection in IS1 DTM	50
3.11.2	Data format	50
3.11.3	Data structure.....	51
3.11.4	Selection of HART Variables	52
3.11.5	HART Livelist	52
3.12	IS1 DTMs	53
3.13	Webserver in IS1 CPU	54
3.14	LED and LCD displays of the CPU	55
3.15	Online behaviour of the IS1 field station.	56
3.15.1	Parameter changes.....	56
3.15.2	Configuration changes.....	56
3.16	Transmission time:	57
4	List of abbreviations:.....	58
5	Release notes:.....	59
6	Further reading	59
7	Support address	59

MODBUS TCP interface description

The historical development of field bus technology at R. STAHL

In the year 1986 R. STAHL SCHALTGERÄTE GMBH brought the ICS MUX field bus system onto the market as the first manufacturer to introduce an I.S. bus system world-wide for the input and output of signals in a potentially explosive atmosphere (Zone 1).

This bus system consists of a master station installed in the control room as the interface partner for automation units together with several completely explosion protected on-site stations or field stations (VOS) installed directly in the field (Zone 1). The connection between the master station and field stations is made via a single coaxial cable.

One of the many highlights of this I.S. bus system is that all the subassemblies of the system - even the power packs – can be plugged or unplugged during operation without affecting the explosion protection. This bus system enabled R. STAHL to present users from the chemical, petrochemical or pharmaceutical industries with an apparatus that can be installed in a potentially explosive atmosphere but that can be operated like an apparatus installed in the control room.

This provided the ideal combination of the technical advantages of field bus technology (simple cabling structures, powerful diagnostic options) with the resulting economical advantages (lower investment costs).

The VOS 200 system variant based on this bus system was introduced in 1993 as a supplement that includes all the recognised advantages of the field bus system and was developed under two fundamental aspects:

- Field bus solution for low signal traffic or decentralised automation units that do not require a master station.
- Standard solution to enable the simple implementation of future standardised bus systems.

The VOS 200 can be coupled to the most varied automation devices in either a redundant or non-redundant configuration as a point-to-point connection or (multi-drop) bus connection.

The principle element of the VOS 200 system variant is the 9503 central unit (CU). This multi-processor subassembly with dual port RAM takes over both the data traffic from and to the connected I/O subassemblies as well as the upwards communication to distributed control systems or programmable logic controllers. The various interface options for the VOS 200 were expanded again in 1997 and supplemented to include a PROFIBUS DP connection.

A further step in optimising this field bus technology was realised in 1999 with the development of the IS1 Remote I/O system. Experience gained from previous systems was used to implement a new, more flexible and more powerful product for the user as well as to provide a solution to all types of automation tasks.

IS1 has been extended in further steps by adding new modules, functions and communication protocols.

The IS1 system was extended in 2008 by SIL2 SAIMH modules which are communicating via PROFIsafe protocol. IS1 is the first zone 1 RIO with PROFIsafe I/O modules worldwide.

The following section describes the system characteristics of the IS1 system when interfaced to an automation system via MODBUS TCP.

MODBUS TCP interface description

1 System overview

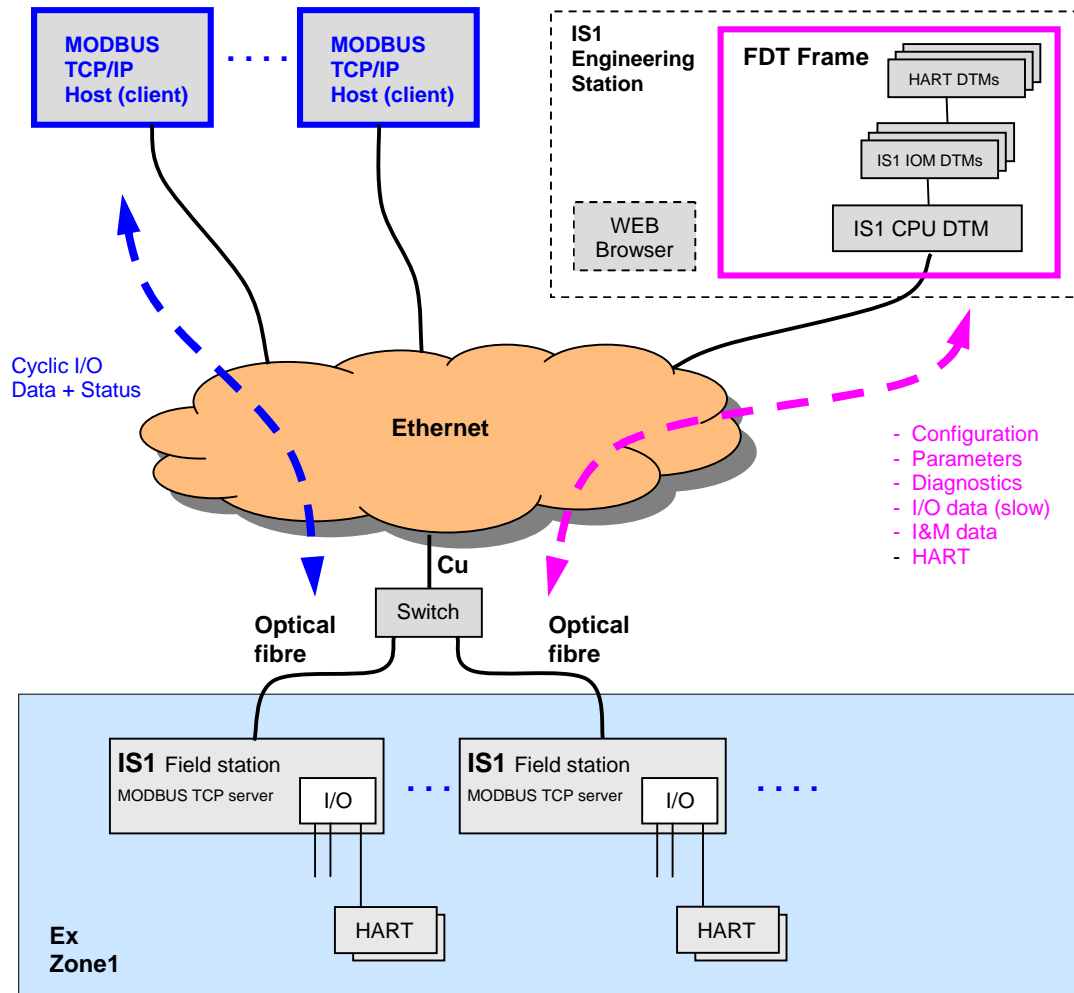

As an off-the-shelf explosion protected unit, the IS1 field station can be installed directly in the potentially explosive atmosphere (Zone 1 or Zone 2). It can also be installed in the safe area. The diagram above shows a Zone 1 solution.

The IS1 field station comes with an Ethernet fibre optic connection and operates as a MODBUS TCP server. Optionally a RS485IS service bus can be used.

Configuration, parameter setting, diagnostics and HART communication for the IS1 field station and its I/O modules are carried out via IS1 DTMs interfaced using FDT technology.

A webserver is integrated in the IS1 CPUs which offers additional diagnostic functions for OEM service support.

MODBUS TCP interface description

Separate networks with Routing via DCS/PLC:

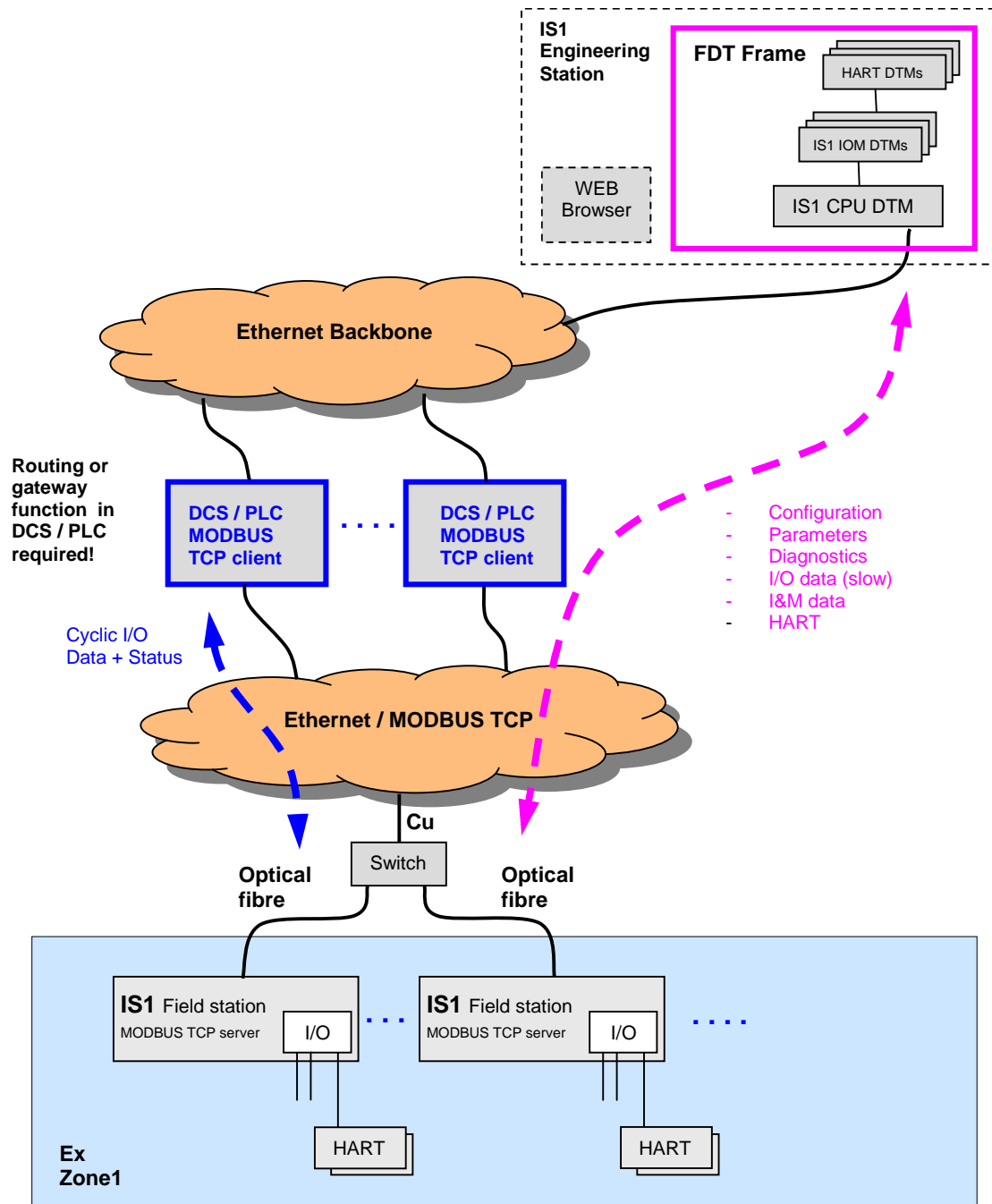

MODBUS TCP interface description

2 Commissioning

2.1 Overview

Planning of the complete MODBUS TCP network:

- Which masters (clients) are in the network
- Which slaves (servers) are in the network
- Selection of network topology and network physics (switches, repeaters, glass fibre links ...)
- Unique allocation of the IP addresses.

Perform the commissioning:

- Mechanical installation of the IS1 field station.
- Mechanical installation of the Ethernet switches
- Mechanical installation of all other bus users.

- Set up the bus connections.

- Set up the voltage supply of the IS1 field station.
- Set up the voltage supply of the switches and other network components

- Set up the IP addresses, Subnet Mask, Gateway.... on the IS1 Fieldstations.
- Set up the addresses of all other users.

- Install a FDT Frame and the IS1 DTMs on the PC.
- Configure the IS1 field stations with its I/O modules using the FDT software.

- Set parameters for the MODBUS TCP clients (masters):
Configuration of MODBUS messages in MODBUS TCP clients according the I/O modules in the IS1 field stations.

- Put the MODBUS master into operation. This results in the automatic start-up of the cyclic client <-> server communication.

- Check Ethernet connection using:
 - LED's on Ethernet Switches
 - Link LED's of CPU on IS1 Fieldstation
 - „Ping“ command. Ping is responding in any CPU state.

- Check communication on the MODBUS TCP using the following tools:
 - Diagnostics information from the client (master) or from the diagnostic tools for the master.
 - LEDs and text display on the CPU of the IS1 field station
 - Webserver in IS1 CPU

- Check I/O signals using the following tools:
 - Information from the client (master) or from the diagnostic tool for the master.
 - Use of diagnostics functions for the IS1 DTMs.

MODBUS TCP interface description

2.2 System requirements

Hardware requirements:

- IS1 field station with CPU 9441/12-00-00
- single socket 9492/12-11-11 or redundant socket 9492/12-11-12

Software requirements:

- CPU firmware MODBUS TCP from revision V21-07 (with redundancy support from V21-08)
- I/O module firmware from revision 2.00 (support for the extended parameter set)
- IS1 DTMs from revision 3.0.0.64

2.3 Engineering limits

The general regulations according to the IS1 operating instructions apply to the engineering of an IS1 field station.

Possible limitations due to MODBUS TCP clients:

- number of I/O modules, the maximum number of signals
- maximum number of slaves in a network

Thus, the limits on the MODBUS TCP clients used must also be taken into account during the engineering.

2.4 Addressing the IS1 field station

The following information is required to address an IS1 field station:

- IP address
- SubNet mask
- optional: Port for the MODBUS server see [Port allocations for MODBUS TCP](#)
- optional: Gateway (only necessary for communication via routers)

The addresses for an IS1 field station can be set via:

- Buttons and display on IS1 CPU.
- IS1 webservice
- The optional MODBUS server port can be set via the IS1 DTMs as a MODBUS parameter.

Attention! The IP addresses must be unique in the network.

Hint: The 'Unit Identifier' address also transferred via MODBUS TCP for serial MODBUS devices from the MBAP header is not used from the IS1 CPU!

MODBUS TCP interface description

2.4.1 BOOTP (Bootstrap Protocol)

IS1 supports the setting of IP Address via BOOTP Protocol according RFC951. The IS1 Fieldstation must be configured in a BOOTP server which must be present on the Ethernet network. The IP-Address for the IS1 CPU must be allocated to its MAC-Address.

After power on the IS1 CPU checks the availability of a BOOTP server on the network and receives its IP address from this BOOTP server. The IP address is stored non volatile in the socket of the IS1 CPU.

If no BOOTP server is detected or the IS1 CPU is not configured in the BOOTP server then the IS1 CPU use the previous non volatile stored IP address.

2.4.2 Address Conflict Detection (ACD)

Double IP addresses in one Ethernet Network can lead to unforeseeable behavior. To detect and to handle such situations ACD according RFC5227 was defined. IS1 is supporting this feature. Additionally the specification 'IPv4 Address Conflict Detection for EtherNet/IPDevices' was considered.

Address conflict during startup:

After power on start up the IS1 CPU checks for other devices with the same IP address on the network. In case of conflict the IS1 CPU stops further standard communication on Ethernet and checks in the background if the conflict is still present.

Address conflict during operation:

Depending on the behavior of the conflict partner the IS1 CPU or the conflict partner can withdraw from communication on Ethernet network.

Behavior of IS1 CPU in case of own withdraw from communication

- Error LED(red) at IS1 CPU = On
- LCD Display: IP conflict stop
- Error Message in event memory of IS1 CPU
- PLC, IS1 Webserver and IS1 DTM: no connection to IS1 CPU

About 1 minute after removal of the IP address conflict through changes on the conflict partner the IS1 CPU will restart its own communication.

Behavior of IS1 CPU in case of withdraw from communication of the communication partner

- No error on Error LED and LCD Display
- IS1 CPU Web-Server: Error message on page 'Protocol':
Two messages toggle in a slow cycle (1 minute):
 - Address Conflict: IP address conflict, defending IP address!
 - Address Conflict: No adress conflict

On each new detection of the address conflict the counter 'Address Conflict detection count' is incremented.

MODBUS TCP interface description

2.5 Port allocations for MODBUS TCP

The MODBUS server in the IS1 CPU supports up to 5 MODBUS Ethernet connections using two Ethernet ports.

One of the two ports is the "MODBUS well known port" 502 which is always available.

The number for the second port can be selected via parameters.

Hint: A change to the port number during operation will close all open Ethernet connections affected by the change. Connections via the default port 502 will remain.

2.6 System start-up behaviour

Configuration data and parameter data for CPU and all I/O modules are generated using the IS1 DTMs, transferred to the IS1 field station by 'download' and are stored in non-volatile memory in the socket for the IS1 CPU.

After power on the entire data range of the output register is initialised with the value 0x8000. All output signals therefore remain in the safe setting.

The remaining data areas are initialised with 0x0000.

After power on the CPU checks that valid configuration data and parameter data are available.

Configuration data and parameter data	Message on the display	CPU state after checking and booting
No data available	No Data Exchange	No data exchange (3)
Data invalid (e.g. CRC error)	Config Error	Config or parameter error (4)
Data valid	Quit Data Exchange	Data exchange with AS quit (5)

If valid data are available, the CPU remains in the state "No data exchange (after power on)", until a start condition is met by messages from the automation system (AS) .

If configuration and parameter data of both CPUs are different, the inactive CPU will go to the Config Error(4) state.

A non-redundant IS1 CPU can be started by any read or write message.

Once a valid message is received, the CPU changes to the state "Data exchange with AS" and the I/O data are exchanged cyclically with the I/O modules configured. The MODBUS register can be accessed from the automation system (AS).

The output signals remain in safe setting until valid output data is written by the AS or by the IS1 DTMs.

Changing I/O modules during operation is possible. After plugging in a new module, parameters are automatically transferred from CPU to the I/O module, followed by a restart of the I/O module. -> Hot swap I/O module.

Exception: Module TIM R 9480/.. : The calibration value for 2 wire operation is stored in the I/O module. After changing of I/O modules a new calibration is required.

MODBUS TCP interface description

2.7 Overview MODBUS Functions

IS1 acts as a MODBUS TCP server according the following specifications:

- MODBUS MESSAGING ON TCP/IP IMPLEMENTATION GUIDE V1.0b
- MODBUS APPLICATION PROTOCOL SPECIFICATION V1.1b

For details of protocol, MODBUS Functions, MODBUS-Error codes see above documents.

The following MODBUS functions are supported by IS1:

MODBUS Functions		Function in IS1	PLC memory area *2)
01 (0x01)	Read Coils	<ul style="list-style-type: none"> • Read Discrete outputs 	0xxxxx
02 (0x02)	Read Discrete Inputs		1xxxxx
03 (0x03)	Read Holding Registers	<ul style="list-style-type: none"> • Read output signals • Read input signals with register offset+1000 	4xxxxx
04 (0x04)	Read Input Registers		3xxxxx
05 (0x05)	Write Single Coil *1)		
06 (0x06)	Write Single Register		
08 (0x08)	Diagnostics Subfunction 0x00 Return-Query Data	<ul style="list-style-type: none"> • Connection check 	
15 (0x0F)	Write Multiple Coils		
16 (0x10)	Write Multiple Registers		
43 (0x2B)	Read Device Identification Read Device ID code = 01 / 02 / 04		

*1) On the usage of the **MODBUS function 5** (Write Single Coil) the following is to be noted:
 After power on or after the loss of the data exchange, the value 0x8000 is written to the output registers in the IS1 CPU and thus the outputs changed to the safe setting. On the subsequent first write operation to such output registers, the complete register is to be overwritten the first time (e.g. using the MODBUS functions 6, 15 or 16) to set all output bits to a defined state. From then on individual bits can be changed using function 5.

*2) Some PLCs / MODBUS TCP clients allocate the Modbus Function indirect via selection of specific memory areas in the PLC. Details see operating instruction of PLC.

MODBUS TCP interface description

2.7.1 MODBUS-FUNCTION 08 - Diagnostics

The subfunction 0 (Return Query Data / LOOPBACK TEST) is supported.

This function can be used to check the physical connection between master (client) and slave (server) without exchange of I/O data.

2.7.2 MODBUS-FUNCTION 43 (0x2B) - Read Device Identification

Object Id	Object Name / Description	Content	Type	category
0x00	VendorName	R. Stahl Schaltgeraete GmbH	ASCII String	Basic
0x01	ProductCode	9441/12-00-00		
0x02	MajorMinorRevision	Rev. xx V yy-yy *1)		
0x03	VendorUrl	www.IS1easy.com		Regular
0x04	ProductName	IS1 remote I/O system		
0x05	ModelName	IS1 CPU		

*1) actual IS1 CPU revision: xx = Hardware Rev., Vyy-yy = Firmware Rev.

Max. object length = 27 bytes

MODBUS TCP interface description

2.8 MODBUS error codes

The error codes transmitted from IS1 to the MODBUS TCP clients in case of errors are according the MODBUS specification.

IS1 MODBUS error codes:

Error Code	Name	Possible Reason	Trouble shooting
0x01	Illegal Function	MODBUS function not implemented	Change MODBUS client message parameters .
0x02	Illegal Data Address	Access outside the MODBUS register limits Reg. 13 ...Reg. 415 Coil 193 ...6640	Change MODBUS client message parameters.
0x03	Illegal Data Value	Error in the message structure	<ul style="list-style-type: none"> • Check quality of transmission on the MODBUS network • Check MODBUS client message parameters
0x04	Slave Device Failure	Hardware error CPU MODBUS memory error	Replace CPU
0x05	Acknowledge	Hardware error CPU (CPU state 1) Other hardware errors	Replace CPU
		No data exchange (CPU state 3) (after power on without config and parameter data)	Download config and parameter data via IS1 DTM into IS1 CPUs
		Configuration or parameter error (CPU state 4)	Check configuration and parameter settings and if necessary download the data via IS1 DTM.
No Response	Timeout in Client	<ul style="list-style-type: none"> • Server (IS1 CPU) is not receiving a request • Server is receiving a request, but has detected a transmission error (parity, CRC) 	<ul style="list-style-type: none"> • Check transmission quality on the MODBUS network • Check parameter settings and function of the MODBUS client

For further information on MODBUS TCP error behaviour see document "MODBUS Application Protocol Specification V1.1b

MODBUS TCP interface description

2.9 MODBUS TCP Multi Client operation

The MODBUS TCP server in IS1 supports multi-client operation with parallel communication with up to max. 5 MODBUS TCP clients.

- Input signals can be read by MODBUS TCP clients as required.
- Output signals are only allowed to be written by one client.
- This situation is not controlled by MODBUS mechanisms!



Attention!

It is the responsibility of the engineer planning the MODBUS TCP clients to ensure individual output signals are not overwritten by several MODBUS TCP clients.

If an output signal is written by several clients with different output values, the related output signal will toggle randomly between the values written.

Behaviour in the case of the failure of cyclic MODBUS TCP connections:

Each of the 5 connections has a dedicated connection monitoring feature.

The time set as IS1 CPU parameter 'Watchdog time AS interface' applies globally to all connections.

If the MODBUS start condition is met on one connection, the CPU changes to the state 'Data Exchange'. This one connection is now monitored for cyclic data traffic for the time set.

Independent of this situation, the start condition can also be met on another connection, as a result the monitoring for cyclic data traffic is also started on this connection.

If the data exchange on one of the active connections is interrupted, the value 0x8000 is output on the entire output image for the IS1 field station.

The output modules retain the previous output data from this point in time until the 'Output modules timeout' has elapsed.

If no new output data have arrived by this time, the output signals switch to the safe setting.

If, prior to the elapse of the 'Output modules timeout' parts of the output signals are overwritten with values other than 0x8000 via Modbus connections that are still established, this data is sent to the related outputs.

Only the data areas not updated change to the safe setting after the elapse of the 'Output modules timeout'.

CPU state

The state of the CPU is displayed in the diagnostics overview CPU in the IS1 DTMs:

CPU state			Behaviour using MODBUS TCP multi client operation.
2	Data exchange with AS	active	State if one or more MODBUS clients are in data exchange
5	Data exchange with AS quit (Exchange with WIZARD/DTM is possible)	active	State if all MODBUS clients have quit data exchange

Detailed information on the status of the different client connections is also available via the webserver in IS1 CPU (see [Webserver in IS1 CPU](#)).

MODBUS TCP interface description

3 Data traffic

3.1 Signal marshalling

The assignment of the signals for a field station to the MODBUS register addresses is performed by an automatic block function for all input and output data. The signals for the I/O modules are placed in data blocks separately for the input and the output area, starting with the slot 1, from a defined MODBUS start address, according to the order of the I/O modules. This process has the advantage, that all data can be read and/or written in one message, where the result is efficient data transmission with a minimum of protocol overhead. The following table shows the data length (registers) for the individual I/O module types.

Module selection in FDT frame	Data length [Registers]	
	Input	Output
9460/12-08-11 AIM 4/8 Exi	8	-
9461/12-08-11 AIMH8 2w Exi	8	-
9461/12-08-11 AIMH8+4HV 2w Exi	16	-
9461/12-08-11 AIMH8+8HV 2w Exi	24	-
9461/12-08-21 AIMH 8 Exi	8	-
9461/12-08-21 AIMH 8 +4HV Exi	16	-
9461/12-08-21 AIMH 8 +8HV Exi	24	-
9461/15-08-12 AIMH8 2w Exn	8	-
9461/15-08-12 AIMH8+4HV 2w Exn	16	-
9461/15-08-12 AIMH8+8HV 2w Exn	24	-
9462/... SAIMH	Usable with PROFIBUS and PROFIsafe only	
9465/12-08-11 AOM 8 Exi	-	8
9466/12-08-11 AOMH 8 Exi	-	8
9466/12-08-11 AOMH 8 +4HV Exi	8	8
9466/12-08-11 AOMH 8 +8HV Exi	16	8
9466/15-08-12 AOMH 8 Exn	-	8
9466/15-08-12 AOMH 8+4HV Exn	8	8
9466/15-08-12 AOMH 8+8HV Exn	16	8
9470/22-16-11 DIM 16 NamExi	2	-
9470/22-16-11 DIM 16+CF NamExi	4	1
9470/25-16-12 DIM 16 Nam Exn	2	-
9470/25-16-12 DIM 16+CF Nam Exn	4	1
9471/10-16-11 DIM 16 24V	2	-
9471/10-16-11 DIM 16+CF 24V	4	1
9471/15-16-12 DIM 16 24V Exn	2	-
9471/15-16-12 DIM 16+CF24V Exn	4	1
9475/12-04-11 DOM 4 Exi1	-	1
9475/12-04-21 DOM 4 Exi2	-	1
9475/12-04-31 DOM 4 Exi3	-	1
9475/12-08-41 DOM 8 Exi1	-	1
9475/12-08-51 DOM 8 Exi2	-	1
9475/12-08-61 DOM 8 Exi3	-	1
9475/12-07-71 DOM 7 Exi4	-	1
9475/22-04-21 DOM 4 OD Exi2	-	1
9475/22-08-51 DOM 8 OD Exi2	-	1
9475/22-08-61 DOM 8 OD Exi3	-	1
9477/10-08-12 DOM 8 Rel	-	1
9477/12-08-12 DOM 8 60V Rel Z1	-	1
9477/12-06-12 DOM 6 250VRel Z1	-	1
9477/15-08-12 DOM 8 Rel Z2	-	1
9478/28-08-51 DOMV 8 OD Exi1	-	1
9480/12-08-11 TIM 8 R Exi	8	-
9481/12-08-11 TIM 8 mV Exi	8	-
AIM 4/8 (9460/..., 9461/..)	8	-
AOM 8 (9465/..., 9466/..)	-	8
DIM 16 (9470/..., 9471/..)	1	-
DOM 4/8 (9475/..)	-	1
Empty module	-	-

MODBUS TCP interface description

3.1.1 Register allocation of I/O data:

Two **separate memory areas** are available for input and output data. The read access to this memory areas can be selected via the different MODBUS functions.

Input signals (DI / AI):

	MODBUS address on interface *2)		MODBUS address in AS and IS1 DTM		Content	Allowed MODBUS functions
	Register Address	Bit (Coil) Address	Register Address	Bit (Coil) Address *1)		
Input data	0x000c (12)	0x00c0 (192)	0x000d (13)	0x00c1 (193)	Signal statuses 1 register per module 1 bit per signal	read: 02 (input coil) or 04 (input register)
	0x001b (27)	0x01b0 (432)	0x001c (28)	0x01b1 (433)		
	0x001c (28)	0x01c0 (448)	0x001d (29)	0x01c1 (449)	Module alarms slot 0 to 15	optional: 03 (holding register) with Register offset +1000
	0x001d (29)	0x01d0 (464)	0x001e (30)	0x01d1 (465)	Module alarms slot 16	
	0x001e (30)	0x01e0 (480)	0x001f (31)	0x01e1 (481)	Status register CPU	
	0x001f...0x019e (31...414)	0x01f0...0x19ef (496...6639)	0x0020...0x019f (32...415)	0x01f1...0x19f0 (497...6640)	Data block input signals	

Output signals (DO / AO):

	MODBUS Address on interface *2)		MODBUS Address in AS and IS1 DTM		Content	Allowed MODBUS functions
	Register Address	Bit (Coil) Address	Register Address	Bit (Coil) Address *1)		
Output data	0x001e (30)	0x01e0 (480)	0x001f (31)	0x01e1 (481)	Control register CPU	read: 01 (output coil) 03 (holding register) write: 05, 15 (coil) 06, 16 (register)
	0x001f...0x019e (31...414)	0x01f0...0x19ef (496...6639)	0x0020...0x019f (32...415)	0x01f1...0x19f0 (497...6640)	Data block output signals	

*1): The MODBUS functions 01, 02, 05 and 15 use coil addresses. The MODBUS functions 03, 04, 06 and 16 use register addresses.

Rule for the least significant bit of a register: **Coil address = (Register address - 1) * 16 + 1**

*2): **Attention!**

In the data telegrams on the interfaces a Register/Coil address decremented by '1' is transmitted from IS1 according MODBUS specification. Some automation systems show the same addresses in the software as they are on the interfaces. In this case the Register- and Coil addresses of the IS1 system must be decremented by one for use in the automation system.

MODBUS TCP interface description

Example:

An IS1 field station is used with the following modules:

Module type:	CPU	DIM16	DIM 16 + CF	DOM 8	AIM 8	AOM 8
Slot:	0	1	2	3	4	5

With this configuration the register address allocations to the signals are as follows:

Input signals			MODBUS address		
Slot	Module type	Signals	Read Register M. Function 4	Read Register M. Function 3	Read Coil M. Function 2
1	DIM 16	DI 0 ... DI 15	32	1032	497 – 512
		Status 0 ... 15	33	1033	513 – 528
2	DIM 16 + CF	DI 0 ... DI 15	34	1034	529 – 544
		Status 0 ... 15	35	1035	545 – 560
		Counter / freq. input 14	36	1036	561 – 576
		Counter / freq. input 15	37	1037	577 – 592
4	AIM	AI 0	38	1038	
		AI 1	39	1039	
		AI 2	40	1040	
		AI 3	41	1041	
		AI 4	42	1042	
		AI 5	43	1043	
		AI 6	44	1044	
		AI 7	45	1045	

Output signals			MODBUS address (read with MODBUS functions 1 or 3, write with MODBUS functions 6, 15 or 16)	
Slot	Module type	Signals	Register read / write	Coil
2	DIM16 + CF	Control register for counter	32	497 – 512
3	DOM 8	DO 0 ... DO 7	33	513 – 528
5	AOM	AO 0	34	
		AO 1	35	
		AO 2	36	
		AO 3	37	
		AO 4	38	
		AO 5	39	
		AO 6	40	
		AO 7	41	

MODBUS TCP interface description

3.1.2 Extract from the allocation table

No.	Address	
	Reg.	Coil
1	32	497 - 512
2	33	513 - 528
3	34	529 - 544
4	35	545 - 560
5	36	561 - 576
6	37	577 - 592
7	38	593 - 608
8	39	609 - 624
9	40	625 - 640
10	41	641 - 656
11	42	657 - 672
12	43	673 - 688
13	44	689 - 704
14	45	705 - 720
15	46	721 - 736
16	47	737 - 752
17	48	753 - 768
18	49	769 - 784
19	50	785 - 800
20	51	801 - 816
21	52	817 - 832
22	53	833 - 848
23	54	849 - 864
24	55	865 - 880
25	56	881 - 896
26	57	897 - 912
27	58	913 - 928
28	59	929 - 944
29	60	945 - 960
30	61	961 - 976
31	62	977 - 992
32	63	993 - 1008
33	64	1009 - 1024
34	65	1025 - 1040
35	66	1041 - 1056
36	67	1057 - 1072
37	68	1073 - 1088
38	69	1089 - 1104
39	70	1105 - 1120
40	71	1121 - 1136
41	72	1137 - 1152
42	73	1153 - 1168
43	74	1169 - 1184
44	75	1185 - 1200
45	76	1201 - 1216
46	77	1217 - 1232
47	78	1233 - 1248
48	79	1249 - 1264
49	80	1265 - 1280
50	81	1281 - 1296
51	82	1297 - 1312
52	83	1313 - 1328
53	84	1329 - 1344
54	85	1345 - 1360
55	86	1361 - 1376
56	87	1377 - 1392
57	88	1393 - 1408
58	89	1409 - 1424
59	90	1425 - 1440
60	91	1441 - 1456
61	92	1457 - 1472
62	93	1473 - 1488
63	94	1489 - 1504
64	95	1505 - 1520

No.	Address	
	Reg.	Coil
65	96	1521 - 1536
66	97	1537 - 1552
67	98	1553 - 1568
68	99	1569 - 1584
69	100	1585 - 1600
70	101	1601 - 1616
71	102	1617 - 1632
72	103	1633 - 1648
73	104	1649 - 1664
74	105	1665 - 1680
75	106	1681 - 1696
76	107	1697 - 1712
77	108	1713 - 1728
78	109	1729 - 1744
79	110	1745 - 1760
80	111	1761 - 1776
81	112	1777 - 1792
82	113	1793 - 1808
83	114	1809 - 1824
84	115	1825 - 1840
85	116	1841 - 1856
86	117	1857 - 1872
87	118	1873 - 1888
88	119	1889 - 1904
89	120	1905 - 1920
90	121	1921 - 1936
91	122	1937 - 1952
92	123	1953 - 1968
93	124	1969 - 1984
94	125	1985 - 2000
95	126	2001 - 2016
96	127	2017 - 2032
97	128	2033 - 2048
98	129	2049 - 2064
99	130	2065 - 2080
100	131	2081 - 2096
101	132	2097 - 2112
102	133	2113 - 2128
103	134	2129 - 2144
104	135	2145 - 2160
105	136	2161 - 2176
106	137	2177 - 2192
107	138	2193 - 2208
108	139	2209 - 2224
109	140	2225 - 2240
110	141	2241 - 2256
111	142	2257 - 2272
112	143	2273 - 2288
113	144	2289 - 2304
114	145	2305 - 2320
115	146	2321 - 2336
116	147	2337 - 2352
117	148	2353 - 2368
118	149	2369 - 2384
119	150	2385 - 2400
120	151	2401 - 2416
121	152	2417 - 2432
122	153	2433 - 2448
123	154	2449 - 2464
124	155	2465 - 2480
125	156	2481 - 2496
126	157	2497 - 2512
127	158	2513 - 2528
128	159	2529 - 2544

No.	Address	
	Reg.	Coil
129	160	2545 - 2560
130	161	2561 - 2576
131	162	2577 - 2592
132	163	2593 - 2608
133	164	2609 - 2624
134	165	2625 - 2640
135	166	2641 - 2656
136	167	2657 - 2672
137	168	2673 - 2688
138	169	2689 - 2704
139	170	2705 - 2720
140	171	2721 - 2736
141	172	2737 - 2752
142	173	2753 - 2768
143	174	2769 - 2784
144	175	2785 - 2800
145	176	2801 - 2816
146	177	2817 - 2832
147	178	2833 - 2848
148	179	2849 - 2864
149	180	2865 - 2880
150	181	2881 - 2896
151	182	2897 - 2912
152	183	2913 - 2928
153	184	2929 - 2944
154	185	2945 - 2960
155	186	2961 - 2976
156	187	2977 - 2992
157	188	2993 - 3008
158	189	3009 - 3024
159	190	3025 - 3040
160	191	3041 - 3056
161	192	3057 - 3072
162	193	3073 - 3088
163	194	3089 - 3104
164	195	3105 - 3120
165	196	3121 - 3136
166	197	3137 - 3152
167	198	3153 - 3168
168	199	3169 - 3184
169	200	3185 - 3200
170	201	3201 - 3216
171	202	3217 - 3232
172	203	3233 - 3248
173	204	3249 - 3264
174	205	3265 - 3280
175	206	3281 - 3296
176	207	3297 - 3312
177	208	3313 - 3328
178	209	3329 - 3344
179	210	3345 - 3360
180	211	3361 - 3376
181	212	3377 - 3392
182	213	3393 - 3408
183	214	3409 - 3424
184	215	3425 - 3440
185	216	3441 - 3456
186	217	3457 - 3472
187	218	3473 - 3488
188	219	3489 - 3504
189	220	3505 - 3520
190	221	3521 - 3536
191	222	3537 - 3552
192	223	3553 - 3568

No.	Address	
	Reg.	Coil
193	224	3569 - 3584
194	225	3585 - 3600
195	226	3601 - 3616
196	227	3617 - 3632
197	228	3633 - 3648
198	229	3649 - 3664
199	230	3665 - 3680
200	231	3681 - 3696
201	232	3697 - 3712
202	233	3713 - 3728
203	234	3729 - 3744
204	235	3745 - 3760
205	236	3761 - 3776
206	237	3777 - 3792
207	238	3793 - 3808
208	239	3809 - 3824
209	240	3825 - 3840
210	241	3841 - 3856
211	242	3857 - 3872
212	243	3873 - 3888
213	244	3889 - 3904
214	245	3905 - 3920
215	246	3921 - 3936
216	247	3937 - 3952
217	248	3953 - 3968
218	249	3969 - 3984
219	250	3985 - 4000
220	251	4001 - 4016
221	252	4017 - 4032
222	253	4033 - 4048
223	254	4049 - 4064
224	255	4065 - 4080
225	256	4081 - 4096
226	257	4097 - 4112
227	258	4113 - 4128
228	259	4129 - 4144
229	260	4145 - 4160
230	261	4161 - 4176
231	262	4177 - 4192
232	263	4193 - 4208
233	264	4209 - 4224
234	265	4225 - 4240
235	266	4241 - 4256
236	267	4257 - 4272
237	268	4273 - 4288
238	269	4289 - 4304
239	270	4305 - 4320
240	271	4321 - 4336
241	272	4337 - 4352
242	273	4353 - 4368
243	274	4369 - 4384
244	275	4385 - 4400
245	276	4401 - 4416
246	277	4417 - 4432
247	278	4433 - 4448
248	279	4449 - 4464
249	280	4465 - 4480
250	281	4481 - 4496
251	282	4497 - 4512
252	283	4513 - 4528
253	284	4529 - 4544
254	285	4545 - 4560
255	286	4561 - 4576
256	287	4577 - 4592

Rule for the least significant bit of a register: **Coil address = (Register address – 1) * 16 + 1**

MODBUS TCP interface description

3.1.3 Rules for message processing:

- MODBUS register limits:
 - Input range – register 13 to 415 (Coil 193 to 6640)
 - Output range – register 13 to 415 (Coil 193 to 6640) and 1013 to 1415Accesses outside the MODBUS register limits are acknowledged with the error message 0x02 'Illegal Data Address'.
- Register areas not configured:
Write messages to register areas not configured are accepted and these data transferred to the register. These data can also be read back. The data are not allocated to the I/O signals on the modules.
- Read and write messages are only processed in CPM state 2 (Data exchange with AS (config + parameters from IS1 DTMs)) and CPM state 5 (left data exchange with AS).
In all other CPM states the error code 0x05 'Acknowledge' is returned.
See also [MODBUS error codes](#)

Exception:

Read access to the status register (reg. 31 input) and write-read access to the control register (reg. 31 output) are always possible.

- For bit-access functions write and read access is possible without consideration of the register limits.

However, it is to be noted:

After power on or after the loss of the data exchange due to a client in the data exchange, the value 0x8000 is written to the output registers in the IS1 CPU and thus all outputs on the module placed in the safe setting. On writing to such an output register next time, the entire register is to be overwritten the first time (e.g. using the MODBUS functions 6, 15 or 16) to place all output bits in a defined state. From then on changes to the individual bits can be updated using function 5.

- A redundant CPU can also be started using start condition 'Write message' by a write message to the control register or an output area that is not configured.
- **Address on interface = address in the AS - 1**
(This is a generally valid MODBUS rule for coil and register addresses)



see hint 2 on page 15 !

MODBUS TCP interface description

3.2 Status register CPU

Through the status register the actual status of the CPU (both CPUs in redundant operation) can be read:

Low Byte:

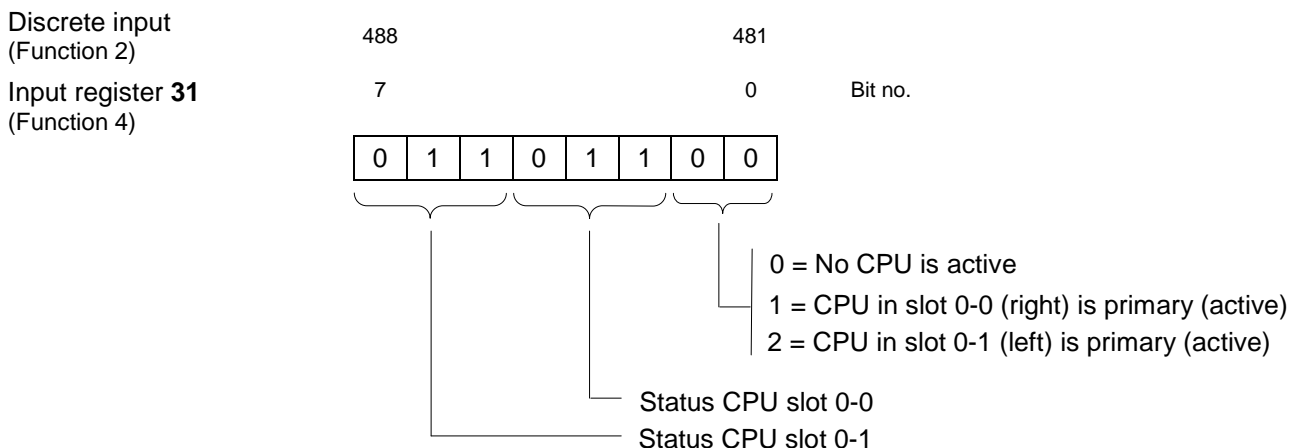

Status CPU:

value 1 (000)	Reserved
value 1 (001)	Hardware error CPU
value 2 (010)	Data exchange with AS (config + parameters from IS1 DTM)
value 3 (011)	No data exchange (after power on without config- and parameter data)
value 4 (100)	Configuration- or parameter failure
value 5 (101)	Data exchange with AS quit (as well after PowerOn, if config- and parameter data are valid)
value 6 (110)	Reserved

High Byte:

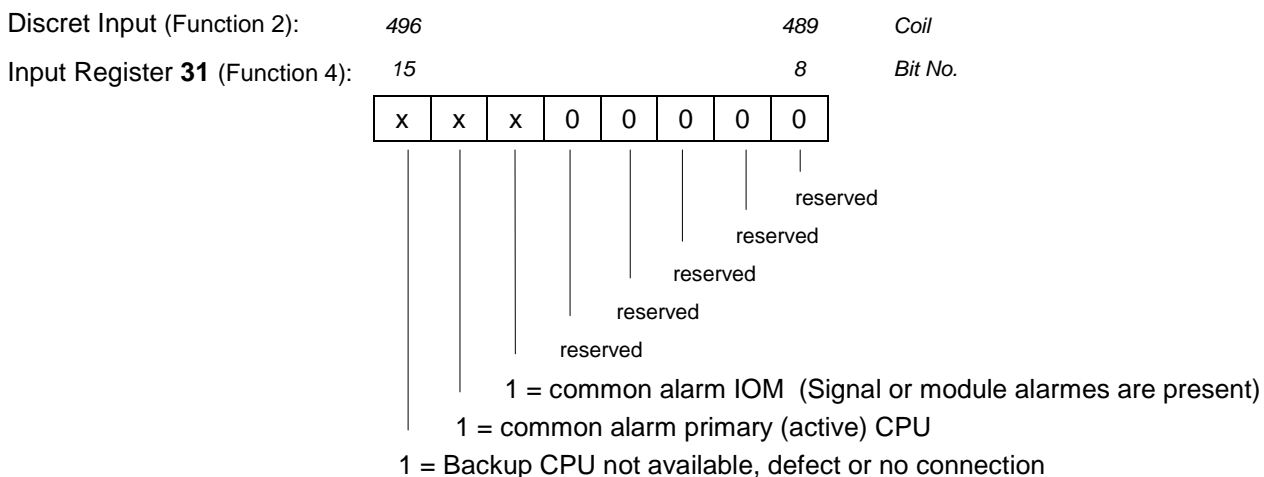

The CPU Status is also shown on the CPU display.

MODBUS TCP interface description

3.3 Control register

One of two redundant CPUs in an IS1 field station can be started by writing from the automation system to the control registers in the CPUs.

Data can be written to the control register using the MODBUS functions 06, 15 and 16.

Control register CPU:

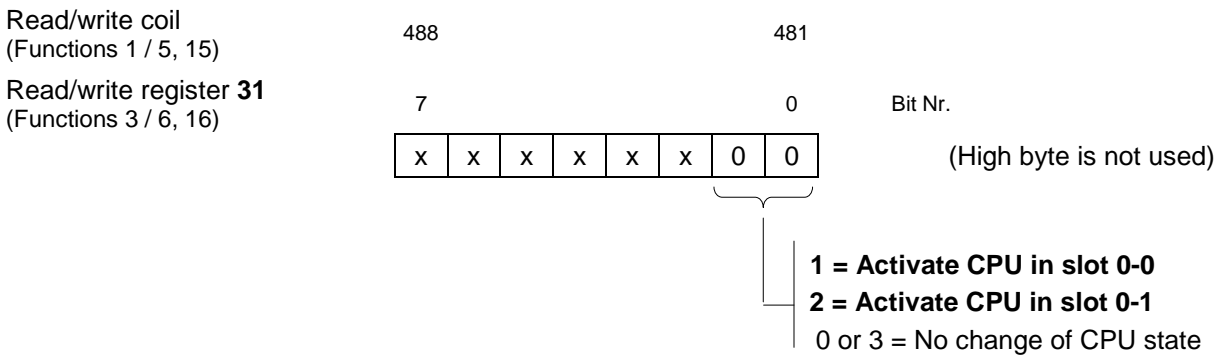

The following parameters must be set if the control register is to be used:

Parameter name	Parameter value
IS1 CPU redundant	- Yes (note 'start condition')
CPU start condition	- Control register

The control register for starting one of two redundant CPUs must be written with identical content to both CPUs (CPU slot 0-0 and slot 0-1).

The CPU selected as primary (active) by the automation system must be continuously controlled with the respective control code (value 1 or 2). This facilitates automatic restart of the CPUs after malfunctions.

MODBUS TCP interface description

3.4 Module alarms

With the MODBUS functions 02 and 04, 2 registers (register address 29 and 30) with module alarms can be read. These registers contain one bit per I/O module with the following allocation:

- Alarm bit = 0 -> No alarms in module. All inputs or outputs on the module are without errors.
- Alarm bit = 1 -> At least one signal alarm (short circuit, open circuit...) or a module alarm is present.

With these alarm bits, alarm messages can be generated in the automation system. For input signals additional status information is available in the cyclic data area (see chapter 3.10 [Signal behaviour in case of errors](#)).

Details of the alarms can be displayed via the IS1 DTMs.

Allocation of the module alarm bits to the registers:

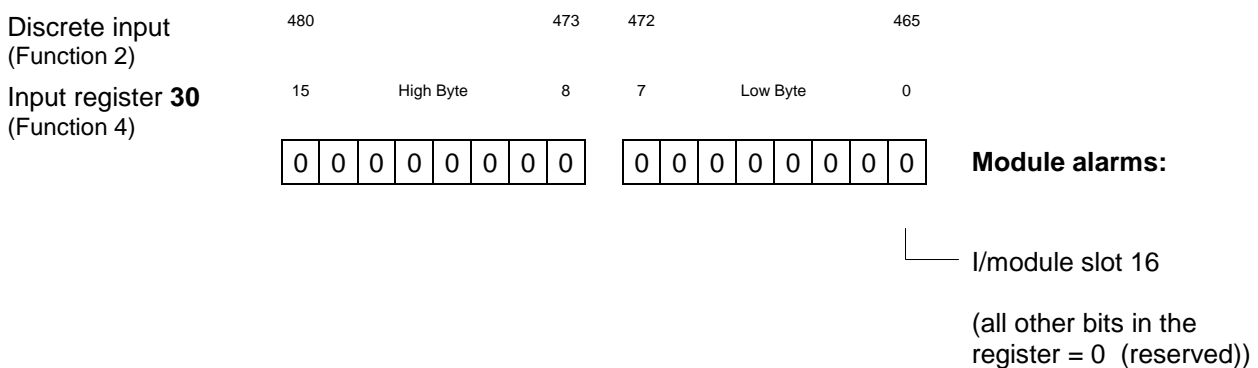
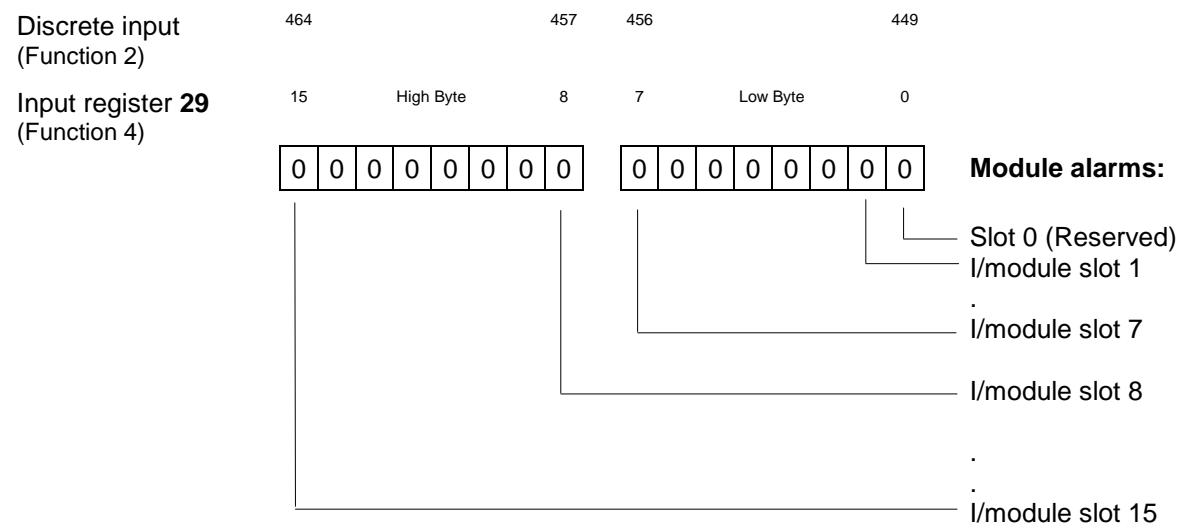

MODBUS TCP interface description

3.5 Signal status

16 registers with signal status information can be read via the MODBUS functions 02 and 04 (register address 13 to 28).

One status bit is provided per signal with the following allocation:

- Status bit = 0 -> No signal malfunction or signal not available. No signal or module alarms present.
- Status bit = 1 -> Signal malfunction (short circuit, open circuit, module error....)

Details of the alarms can be displayed via the IS1 DTMs.

Register allocation:

Input register (Function 4)	Discrete inputs (Function 2)	208	High Byte							201	200	Low Byte							193	Discrete inputs in reg 13
		15							8	7							0	Bit No.		
13	193 - 208	S15	S8	S7	S0	Slot 1
14	209 - 224	S15	S8	S7	S0	Slot 2
15	225 - 240	S15	S8	S7	S0	Slot 3
16	241 - 256	S15	S8	S7	S0	Slot 4
17	257 - 272	S15	S8	S7	S0	Slot 5
18	273 - 288	S15	S8	S7	S0	Slot 6
19	289 - 304	S15	S8	S7	S0	Slot 7
20	305 - 320	S15	S8	S7	S0	Slot 8
21	321 - 336	S15	S8	S7	S0	Slot 9
22	337 - 352	S15	S8	S7	S0	Slot 10
23	353 - 368	S15	S8	S7	S0	Slot 11
24	369 - 384	S15	S8	S7	S0	Slot 12
25	385 - 400	S15	S8	S7	S0	Slot 13
26	401 - 416	S15	S8	S7	S0	Slot 14
27	417 - 432	S15	S8	S7	S0	Slot 15
28	433 - 448	S15	S8	S7	S0	Slot 16

MODBUS TCP interface description

3.6 CPU Redundancy

Redundant operation of two CPU in one field station is supported from Firmware Revision V21-08.

3.6.1 Non redundant Ethernet Network

Redundant IS1 CPUs can be connected to a not redundant Ethernet Network.

The IP-Addresses of both CPUs must be different.

The control of the redundancy must be handled in the DCS/PLC application.

Input Data can be read from both CPUs.

One of the two CPUs can be switched to the primary state via the control register or other write telegrams.

Valid output data must be written to the primary CPU. (see [Control register](#) and [CPU parameters](#)).

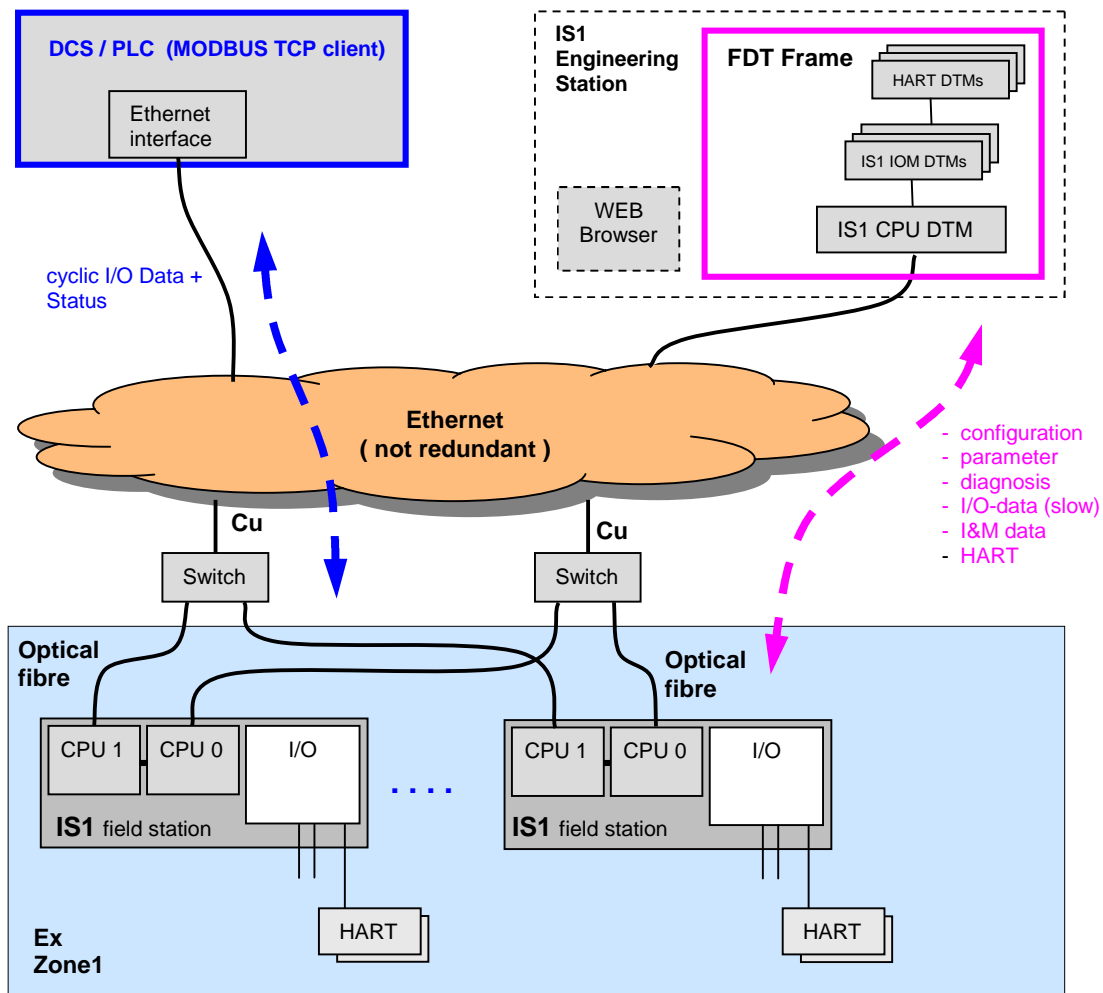

Connection of the IS1 Engineering Station:

The IS1 Engineering Station is connected to one of the two CPUs. Communication and diagnosis data off the other CPU can be accessed via a link between both CPUs.

MODBUS TCP interface description

3.6.2 Redundant Ethernet Networks

If redundant Ethernet networks shall be used, the MODBUS TCP client must support redundant Ethernet interfaces.

Network structure:

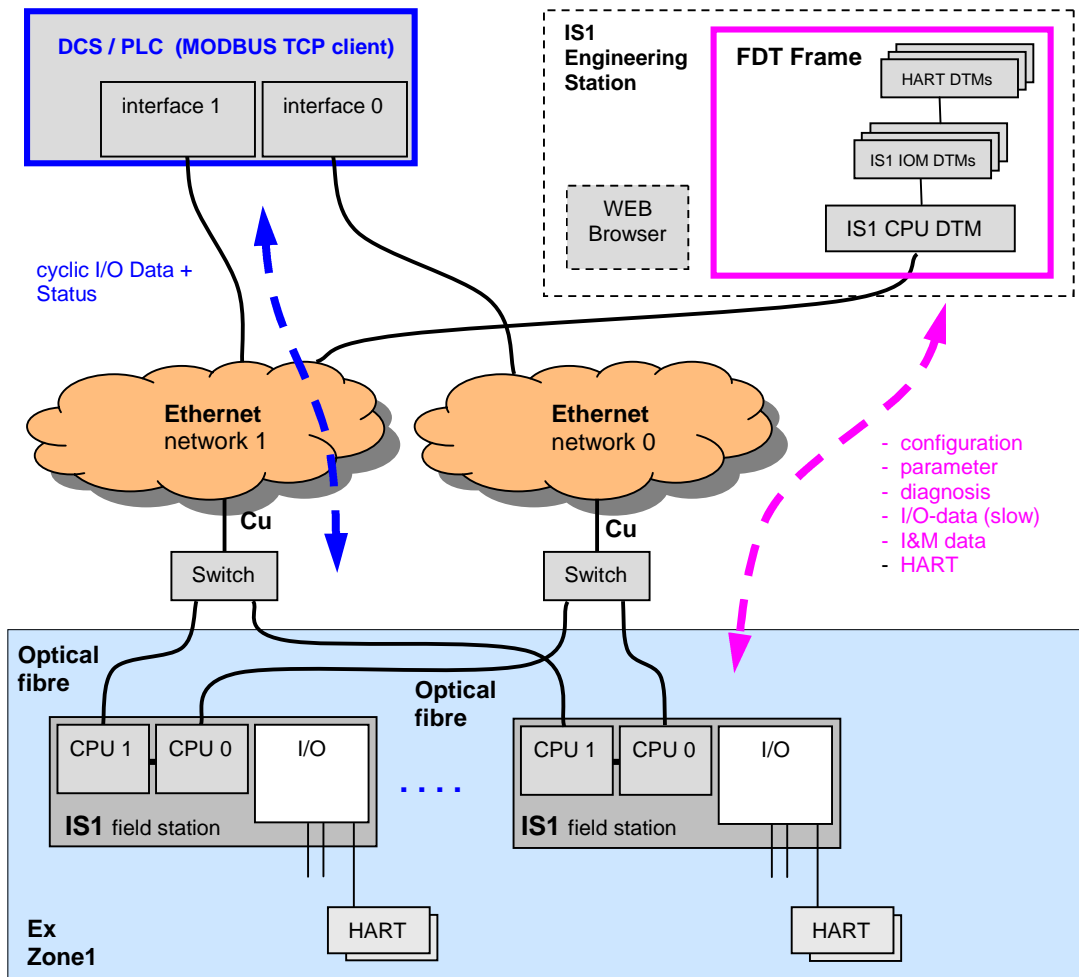

Connection of the IS1 Engineering Station:

The IS1 Engineering Station must be connected to one of the two networks and has only access to one of the two CPUs. Configuration-, parameter and diagnosis data of both CPUs are synchronized via a link between both CPUs and are available for the DTM.

With the Event History Tool only data from the connected CPU can be accessed. If data from both CPUs are requested, the IS1 engineering PC must be connected alternately to each of the two networks to read the data.

A connection of both networks to one single network is not allowed!

MODBUS TCP interface description

3.6.3 Ethernet IP Addresses:

Depending on the requirements and the planning for the AS (MODBUS TCP clients) the IP addresses for the two redundant IS CPUs can be set the same (only on usage of redundant networks) or may be different (e.g. if both IS1 CPUs are connected to one network).

3.6.4 Parameterisation:

When setting the parameters for the CPU, the parameter **'IS1 CPU redundant = Yes'** is to be selected in the IS1 DTMs for redundant operation.

In this case the parameter **'CPU start condition'** is effective.

If the parameter **'IS1 CPU redundant = No'** has been selected, one CPU will start for all write and read messages except MODBUS function 8 (loopback).

For correct redundancy switching in case of a malfunction on the active interface, the parameter **'Output modules timeout'** is to be set larger than the maximum switching time from the active IS1 CPU to the inactive IS1 CPU. This switching time is dependent on the behaviour of the master (MODBUS TCP client) as well as on the Ethernet networks.

If the parameter **'Output modules timeout'** is set too low, output signals will briefly change to the safe setting during switching.

3.6.5 Selection of 'CPU start condition'

The automation system (AS) selects one of the redundant interfaces for active (primary) and the other interface for backup operation. I/O Data is transferred only via the active interface. The selection of the active interface in the AS must be synchronized with the redundant IS1 CPUs.

The IS1 CPUs monitor different behavior of the two redundant interfaces of the AS as **'CPU start condition'**

After detection of a valid start condition on its interface each IS1 CPU changes to active operation.

This synchronization of the active IS1 CPU with the active interface of the AS must be ensured in all cases, even if e.g. only Input data are read.

The **'CPU start condition'** must only be fulfilled on the active interface of the MODBUS Masters.

Depending on the behaviour of the MODBUS Master on the inactive interface and the data telegrams on the active interface the parameter **'CPU start condition'** has to be selected:

Data traffic on the primary (active) interface	Data traffic on the backup (inactive/standby) interface	Select parameter 'CPU start condition'
R/W	Loopback	Read telegramm or Write telegramm
R	Loopback	Read telegramm
W	Loopback	Write telegramm
R/W	R	Write telegramm
W	R	Write telegramm
R	R	Control register
R/W	R/W	Control register

R = Read (MODBUS functions 1, 2, 3 or 4)

W = Write (MODBUS functions 6, 15 or 16)

MODBUS TCP interface description

Attention! If the CPU start condition is fulfilled on both CPUs at the same time, so both CPUs try to start. Both CPU must not be primary (active) at the same time. Via interacted interlocking at the MODBUS traffic of the already started CPU will be stopped for 5 seconds by a new started CPU. In such a case both CPU toggle after app. 5 Sec. between primary and backup state.

Startup:

After power on the CPU started first becomes the primary (active). The other CPU becomes the backup (inactive).

The state is indicated on the LC display.

All output modules remain in the safe setting.

All input modules supply cyclic input signals if valid configuration and parameter data are available.

On the first receive of a telegram, which fulfills the 'CPU start condition' the CPU will change to the state data exchange and monitors the cyclic data exchange of I/O data.

With a 'Write message' start condition a redundant CPU can also be started by a write message to an output area that is not configured.

3.6.6 Download of Configuration and Parameter data to redundant CPUs

Independent of the state of the two CPUs (primary / backup) the access from the IS1 Engineering Station to the connected CPU is possible.

The configuration and parameter data generated with the IS1 DTMs are transmitted via Ethernet with the function 'download' to both CPUs of a redundant IS1 fieldstation and are stored permanent in the socket of the CPU. If parameters are changed online with the IS1 DTMs, the changed data are also stored in both CPUs.

So that the replacement of a CPU does not result in the loss of the configuration, and in the event of a configuration error, a download is required; it will not be possible to rectify the error by replacing a CPU.

If only one CPU is in operation, newly loaded data can only be saved in the socket for this one CPU. If the second CPU is placed in operation later, without shutting down the first CPU after the download, the newly loaded data will be automatically copied to the socket for the new CPU.

If both CPUs are running after power on, the CPU that starts first uses the data available to it and starts to operate. The CPU starting later compares the data available to it with the data for the CPU already running. In the case of identical data, this CPU goes into operation and the backup state.

If there are discrepancies in the data, this CPU does not go into operation and signals a config/parameter error:

- Green LED flashes, red LED on
- LCD: Konfig/Param. Error
- DTM diagnostics overview indicates CPU state 4

In this case it is necessary to download from IS1 DTM again.

3.6.7 HART

The HART communication between the IS1 DTMs and HART field devices is only possible via the primary CPU and the HART livelist can only be read via the primary CPU. If the IS1 DTMs are connected to the backup CPU, the HART data traffic will be rejected with transmission errors. HART communication is possible immediately after power on without the operation of the MODBUS. Due to a MODBUS start condition, switching of the CPUs may take place that results in the loss of the HART communication.

MODBUS TCP interface description

3.6.8 Diagnosis using IS1 DTMs

Diagnostics data, input signals and I&M data are available in both IS1 CPUs (primary and backup) and can be read by the IS1 DTMs from both CPUs.

It is only possible to read output data from the primary CPU.

In the case of the operation of an IS1 field station without AS, it is only possible to write output data from the IS1 DTMs to the primary CPU. A connected CPU can be placed in the primary state with a download from the IS1 DTMs.

3.6.9 WEB Server der IS1 CPUs

Both IS1 CPUs have their own WEB Server and distribute the available information of the accessed CPU.

3.6.10 Process data of CPUs during redundancy switch over

During standard operation of two redundant CPUs the input signals in the memory of the backup CPU are cyclically updated by the primary CPU.

MODBUS TCP interface description

3.6.11 State of redundant CPU

There is an LC display in a redundant socket. Data from both CPUs can be displayed. The CPU to be displayed is to be selected on the menu. For detailed information on the LCD menu as well as the LED indications for the CPUs, see the operating instructions for the IS1 CPU.

On the LC display the address of the **primary CPU** can be seen at the top left of the main menu:

CPU 0-0 Right CPU is primary
 CPU 0-1 Left CPU is primary

Examples for states displayed:

CPU	primary	backup	Function -> Action
State	Data exchange with AS (2)	--	Primary CPU OK. No error. CPU cyclically updates I/O data using the I/O modules as well as via MODBUS TCP. The connection to the AS is monitored for all read and write messages as per parameter 'Watchdogtime AS interface'.
LCD	DataExch	--	
LED	RUN: on ERR: off	--	
State	--	Data exchange with AS (2)	Backup CPU communicating with cyclic messages (read or loopback) The connection to the AS is monitored: - For read messages as per parameter 'Watchdogtime AS interface'. In case of loss of connection -> data exchange with AS quit (5)
LCD	--	DataExch	
LED	--	RUN: on ERR: off	
State	Data exchange with AS quit (5)	--	No data exchange present! After power on, if valid configuration data are available or if 'Watchdogtime AS interface' has elapsed. Outputs are in the safe setting. -> Check: - LINK LED (OK if on or flashing) - Ethernet hardware connection (e.g. PING) - MODBUS TCP master (client) active? - Parameters set in AS and IS1 field station: - IP address, subnet mask, gateway, port - Monitoring time too short?
LCD	QuitDataExch	--	
LED	RUN: flashing ERR: flashing inverted	--	
State	Data exchange with AS (2)	--	There are module errors! CPU is OK. (incorrect module, I/O module not responding ...). I/O alarms are displayed on the LEDs for the I/O module. -> Rectify module error!
LCD	DataExch	--	
LED	RUN: on ERR: flashing	--	
State	No data exchange (3)	No data exchange (3)	No configuration data or parameter data saved in the two CPUs. -> Perform download using the IS1 DTMs.
LCD	NoDataExch	NoDataExch	
LED	RUN: flashing ERR: off	RUN: flashing ERR: off	

MODBUS TCP interface description

CPU	primary	backup	Function -> Action
State	Configuration or parameter error (4)	--	Configuration or parameter error. No valid configuration data or parameter data saved in the CPU. -> Perform download using the IS1 DTMs.
LCD	Config error	--	
LED	RUN: flashing ERR: on	--	
State	--	Hardware Error	CPU hardware error. If a hardware error occurs in a CPU, the other CPU automatically becomes the primary CPU. This can indicate the state of the faulty backup CPU. -> Replace faulty CPU.
LCD	--	Hardware Error	
LED	--	RUN: off ERR: on	
State	Data exchange with AS (2)		The system parameters are set for redundancy. The backup CPU has failed or is not fitted. The primary CPU continues to work normally. -> Replace backup CPU or fit and place in operation
LCD	DataExch	"—"	
LED	RUN: on ERR: flashing		
State	Data exchange with AS (2)	--	The system parameters are not set for redundancy. However two CPUs have been fitted: The primary CPU continues to work normally. <ol style="list-style-type: none"> Continued operation without redundant CPUs: -> Remove backup CPU or: Change to operation with redundant CPUs: -> Configure system with redundant CPUs and download from DTM while both CPUs are fitted and in operation.
LCD	DataExch	noBackup	
LED	RUN: on ERR: flashing	--	

--	Any state
----	-----------

MODBUS TCP interface description

3.6.12 Prepared / deactivated redundancy

To prepare for future CPU redundancy or to deactivate redundancy, a redundant socket can be installed and only one CPU fitted in one of the two sockets.

CPU parameter setting: 'IS1 CPU redundant' = No

The mutual checking and provision of alarms in case of an error performed by redundantly operated CPUs is deactivated in this case.

Attention!

If two redundant CPUs are fitted and the parameter 'IS1 CPU redundant' = No is selected, then in the high byte of the status register the bit 'Backup CPU not available, defect or no connection' is set. The LEDs for the CPUs indicate the state DataExchange 'Module alarm'.

3.7 Setting parameters for the IS1 field station and the I/O modules

Configuration, parameter setting, diagnostics and HART communication for the IS1 field stations is handled via the IS1 DTMs using FDT technology.

Example:

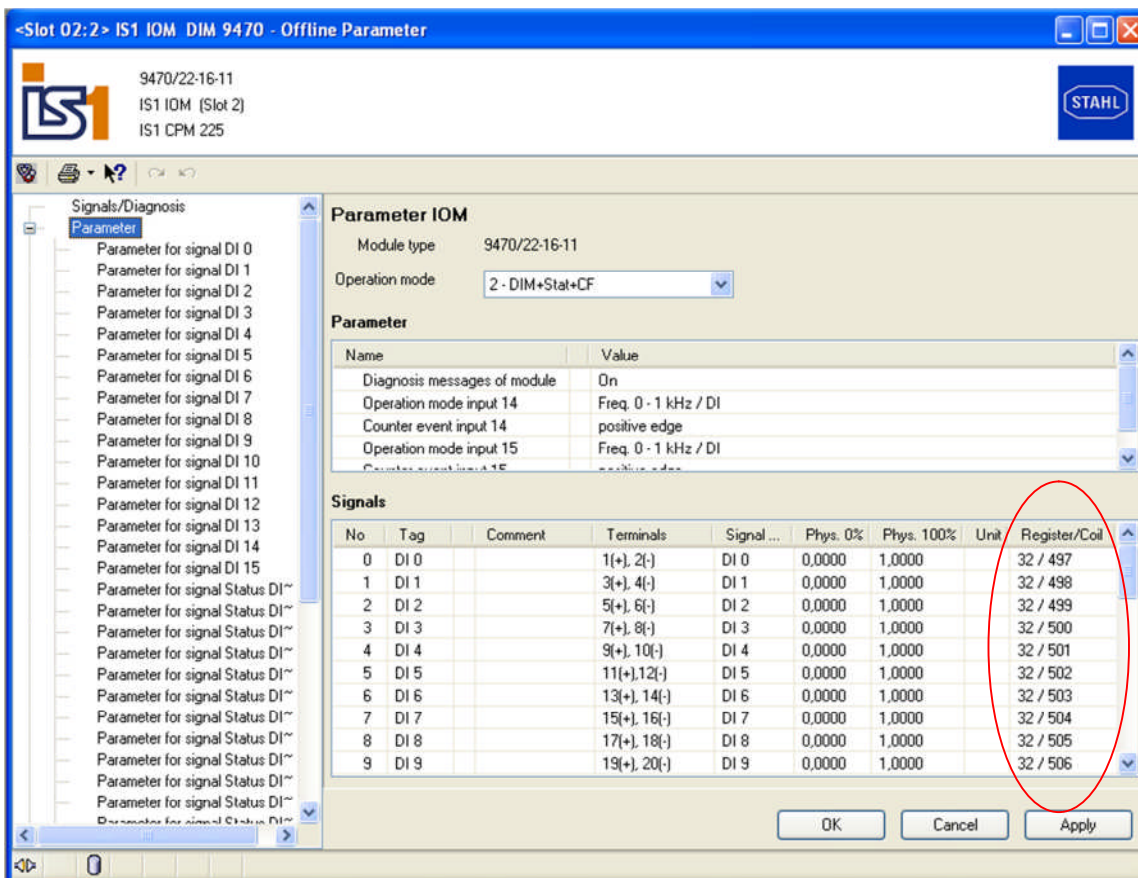

For further information on the use of the IS1 DTMs see operating instructions 'DTM IS1 Mod'.

MODBUS TCP interface description

3.8 Extended parameter set for IS1

3.8.1 CPU parameters

Parameter name	Parameter value	(bold = default)
Watchdogtime AS interface T_{WD} (x 100 ms) *1)	Unsigned8 (0 - 255) (0 = Watchdog Off)	Default: 20
Timeout for output modules T_{Mod} (x 100 ms) *4)	Unsigned8 (1 - 255)	Default: 1
IS1 CPU redundant	- No (Parameter 'Start condition' not used.) - Yes (note 'start condition')	
CPU start condition *2)	- MODBUS read message (01, 02, 03, 04) - MODBUS write message (06, 15, 16) - Control register	
Alternative MODBUS port *3)	Unsigned16 (502 - 65535)	Default: 502

*1) **Attention:** A change to the parameter Watchdogtime AS interface in operation will result in a brief interruption and re-initialisation of all existing MODBUS connections.

*2) This parameter is active only in case of redundant operation with 2 CPU's in one field station. In non-redundant operation (only one CPU in a field station) the CPU starts with every MODBUS read or write message except MODBUS function 8 (loopback).

*3) Communication via the MODBUS default port 502 is always possible. Additionally communication via the alternative MODBUS port is possible.

*4) See Application Hint in chapter 3.10.2

MODBUS TCP interface description

3.8.2 I/O module parameters

3.8.2.1 AIM / AIMH

Parameter	Default value	Value range / selection
Diagnostic messages of the module	On	Off On
Input filter	Medium	Small Medium Big (50 Hz) Big (60 Hz)
Signal in case of error I 0	Alarm code	-10 % (4 mA only) 0 % 100 % Alarm code Freeze (initial value 0%) Freeze (initial value 100%)
Signal in case of error I 1	Alarm code	
Signal in case of error I 2	Alarm code	
Signal in case of error I 3	Alarm code	
Signal in case of error I 4	Alarm code	
Signal in case of error I 5	Alarm code	
Signal in case of error I 6	Alarm code	
Signal in case of error I 7	Alarm code	
Error detection I 0	On	Off On
Error detection I 1	On	
Error detection I 2	On	
Error detection I 3	On	
Error detection I 4	On	
Error detection I 5	On	
Error detection I 6	On	
Error detection I 7	On	
Input range I 0	4...20 mA	0...20 mA 4...20 mA
Input range I 1	4...20 mA	
Input range I 2	4...20 mA	
Input range I 3	4...20 mA	
Input range I 4	4...20 mA	
Input range I 5	4...20 mA	
Input range I 6	4...20 mA	
Input range I 7	4...20 mA	
Measurem. range ac. NAMUR I 0	No	No Yes
Measurem. range ac. NAMUR I 1	No	
Measurem. range ac. NAMUR I 2	No	
Measurem. range ac. NAMUR I 3	No	
Measurem. range ac. NAMUR I 4	No	
Measurem. range ac. NAMUR I 5	No	
Measurem. range ac. NAMUR I 6	No	
Measurem. range ac. NAMUR I 7	No	
Scan HART livelist	On	Off On
Input No. HART device for pos. 1	Not used	0...7 'Not used'
Input No. HART device for pos. 2	Not used	
Input No. HART device for pos. 3	Not used	
Input No. HART device for pos. 4	Not used	
Input No. HART device for pos. 5	Not used	
Input No. HART device for pos. 6	Not used	
Input No. HART device for pos. 7	Not used	
Input No. HART device for pos. 8	Not used	
No. HART variable for pos. 1	HART variable No. 2	HART variable No. 1 HART variable No. 2 HART variable No. 3 HART variable No. 4
No. HART variable for pos. 2	HART variable No. 2	
No. HART variable for pos. 3	HART variable No. 2	
No. HART variable for pos. 4	HART variable No. 2	
No. HART variable for pos. 5	HART variable No. 2	
No. HART variable for pos. 6	HART variable No. 2	
No. HART variable for pos. 7	HART variable No. 2	
No. HART variable for pos. 8	HART variable No. 2	

Default values in **'bold'**

Available only on HART modules (AIMH) !

3.8.2.2 TIMR

MODBUS TCP interface description

Parameter	Default value	Value range / selection
Diagnostic messages of the module	On	Off On
Input filter	50 Hz	50 Hz 60 Hz Off (not recommended)
Operation mode	8 inputs	8 inputs 2 inputs
Signal in case of error I 0	Alarm code	Alarm code Freeze (initialisation value 0%)
Signal in case of error I 1	Alarm code	
Signal in case of error I 2	Alarm code	
Signal in case of error I 3	Alarm code	
Signal in case of error I 4	Alarm code	
Signal in case of error I 5	Alarm code	
Signal in case of error I 6	Alarm code	
Signal in case of error I 7	Alarm code	
Error detection I 0	On	Off On
Error detection I 1	On	
Error detection I 2	On	
Error detection I 3	On	
Error detection I 4	On	
Error detection I 5	On	
Error detection I 6	On	
Error detection I 7	On	
Type I 0	Pt 100	Pt100 Pt500 Pt1000 Ni100 Ni500 Ni1000 Resistance 10k Resistance 5k Resistance 2k5 Resistance 500R Pt100 GOST M50 GOST M100 GOST Cu53 GOST Pt46 GOST Pt50 GOST
Type I 1	Pt 100	
Type I 2	Pt 100	
Type I 3	Pt 100	
Type I 4	Pt 100	
Type I 5	Pt 100	
Type I 6	Pt 100	
Type I 7	Pt 100	
Connection I 0	4 wire	2 wire 3 wire 4 wire
Connection I 1	4 wire	
Connection I 2	4 wire	
Connection I 3	4 wire	
Connection I 4	4 wire	
Connection I 5	4 wire	
Connection I 6	4 wire	
Connection I 7	4 wire	

MODBUS TCP interface description

3.8.2.3 TIM mV

Parameter	Default value	Value range / selection
Diagnostic messages of the module	On	Off On
Input filter	50 Hz	50 Hz 60 Hz
Signal in case of error I 0	Alarm code	Alarm code Freeze (initialisation value 0%)
Signal in case of error I 1	Alarm code	
Signal in case of error I 2	Alarm code	
Signal in case of error I 3	Alarm code	
Signal in case of error I 4	Alarm code	
Signal in case of error I 5	Alarm code	
Signal in case of error I 6	Alarm code	
Signal in case of error I 7	Alarm code	
Error detection I 0	On	Off On
Error detection I 1	On	
Error detection I 2	On	
Error detection I 3	On	
Error detection I 4	On	
Error detection I 5	On	
Error detection I 6	On	
Error detection I 7	On	
Type I 0	THC Type K	0...100 mV THC Type B THC Type E THC Type J THC Type K THC Type N THC Type R THC Type S THC Type T THC Type L THC Type U THC Type XK (L)
Type I 1	THC Type K	
Type I 2	THC Type K	
Type I 3	THC Type K	
Type I 4	THC Type K	
Type I 5	THC Type K	
Type I 6	THC Type K	
Type I 7	THC Type K	
Input signal I 0	Balanced	Balanced Unbalanced
Input signal I 1	Balanced	
Input signal I 2	Balanced	
Input signal I 3	Balanced	
Input signal I 4	Balanced	
Input signal I 5	Balanced	
Input signal I 6	Balanced	
Input signal I 7	Balanced	

MODBUS TCP interface description

3.8.2.4 DIM

Parameter	Default value	Value range / selection
Diagnostic messages of the module	On	Off On
Signal in case of error I 0	0	0 1 Freeze (initial value 0) Freeze (initial value 1)
Signal in case of error I 1	0	
Signal in case of error I 2	0	
Signal in case of error I 3	0	
Signal in case of error I 4	0	
Signal in case of error I 5	0	
Signal in case of error I 6	0	
Signal in case of error I 7	0	
Signal in case of error I 8	0	
Signal in case of error I 9	0	
Signal in case of error I 10	0	
Signal in case of error I 11	0	
Signal in case of error I 12	0	
Signal in case of error I 13	0	
Signal in case of error I 14	0	
Signal in case of error I 15	0	
Error detection I 0	On	Off On
Error detection I 1	On	
Error detection I 2	On	
Error detection I 3	On	
Error detection I 4	On	
Error detection I 5	On	
Error detection I 6	On	
Error detection I 7	On	
Error detection I 8	On	
Error detection I 9	On	
Error detection I 10	On	
Error detection I 11	On	
Error detection I 12	On	
Error detection I 13	On	
Error detection I 14	On	
Error detection I 15	On	
Invert I 0	No	No Yes
Invert I 1	No	
Invert I 2	No	
Invert I 3	No	
Invert I 4	No	
Invert I 5	No	
Invert I 6	No	
Invert I 7	No	
Invert I 8	No	
Invert I 9	No	
Invert I 10	No	
Invert I 11	No	
Invert I 12	No	
Invert I 13	No	
Invert I 14	No	
Invert I 15	No	

Parameters not present on DIM 24 V ! (9471/...)

MODBUS TCP interface description

Pulse extension I 0	0 Sec.	
Pulse extension I 1	0 Sec.	
Pulse extension I 2	0 Sec.	
Pulse extension I 3	0 Sec.	
Pulse extension I 4	0 Sec.	
Pulse extension I 5	0 Sec.	
Pulse extension I 6	0 Sec.	0 s
Pulse extension I 7	0 Sec.	0.6 s
Pulse extension I 8	0 Sec.	1.2 s
Pulse extension I 9	0 Sec.	2.4 s
Pulse extension I 10	0 Sec.	
Pulse extension I 11	0 Sec.	
Pulse extension I 12	0 Sec.	
Pulse extension I 13	0 Sec.	
Pulse extension I 14	0 Sec.	
Pulse extension II 15	0 Sec.	
Operation mode I 14	Freq. 0-1 kHz / DI	Counter Freq. 0-1 kHz / DI Freq. 0-20 kHz gate 50 ms / DI Freq. 0-20 kHz gate 200 ms / DI Freq. 0-20 kHz gate 1 s / DI
Counter event I 14	Positive edge	Positive edge Negative edge
Operation mode I 15	Freq. 0-1 kHz / DI	s. a.
Counter event I 15	Positive edge	s. a.

Parameters available only in the case of operating mode DIM16 + CF!

MODBUS TCP interface description

3.8.2.5 AOM / AOMH

Parameter	Default value	Value range / selection
Diagnostic messages of the module	On	Off On
Signal in case of error O 0	0 %	-10 % (4 mA only) 0 % 100 % 110 % Freeze
Signal in case of error O 1	0 %	
Signal in case of error O 2	0 %	
Signal in case of error O 3	0 %	
Signal in case of error O 4	0 %	
Signal in case of error O 5	0 %	
Signal in case of error O 6	0 %	
Signal in case of error O 7	0 %	
Error detection O 0	On	Off On
Error detection O 1	On	
Error detection O 2	On	
Error detection O 3	On	
Error detection O 4	On	
Error detection O 5	On	
Error detection O 6	On	
Error detection O 7	On	
Output range O 0	4...20 mA	0...20 mA 4...20 mA
Output range O 1	4...20 mA	
Output range O 2	4...20 mA	
Output range O 3	4...20 mA	
Output range O 4	4...20 mA	
Output range O 5	4...20 mA	
Output range O 6	4...20 mA	
Output range O 7	4...20 mA	
Scan HART livelist	On	Off On
Output No. HART device for pos. 1	Not used	0...7 Not used
Output No. HART device for pos. 2	Not used	
Output No. HART device for pos. 3	Not used	
Output No. HART device for pos. 4	Not used	
Output No. HART device for pos. 5	Not used	
Output No. HART device for pos. 6	Not used	
Output No. HART device for pos. 7	Not used	
Output No. HART device for pos. 8	Not used	
No. HART variable for pos. 1	HART variable No. 2	HART variable No. 1 HART variable No. 2 HART variable No. 3 HART variable No. 4
No. HART variable for pos. 2	HART variable No. 2	
No. HART variable for pos. 3	HART variable No. 2	
No. HART variable for pos. 4	HART variable No. 2	
No. HART variable for pos. 5	HART variable No. 2	
No. HART variable for pos. 6	HART variable No. 2	
No. HART variable for pos. 7	HART variable No. 2	
No. HART variable for pos. 8	HART variable No. 2	

Available only on HART modules (AOMH) !

MODBUS TCP interface description

3.8.2.6 DOM

Parameter	Default value	Value range / selection	Parameter available		
			DOM	DOMR	DOMV
Diagnostic messages of the module	On	Off On	✓	✓	✓
Signal in case of error O 0	0	0 1 Freeze	✓	✓	✓
Signal in case of error O 1	0				
Signal in case of error O 2	0				
Signal in case of error O 3	0				
Signal in case of error O 4	0				
Signal in case of error O 5	0				
Signal in case of error O 6	0				
Signal in case of error O 7	0				
Error detection O 0	On	Off On without test current On	✓	-	-
Error detection O 1	On				
Error detection O 2	On				
Error detection O 3	On				
Error detection O 4	On				
Error detection O 5	On				
Error detection O 6	On				
Error detection O 7	On				
Output 0 and 1 parallel	Outputs separate	Outputs separate Outputs parallel	✓	✓	-
Output 2 and 3 parallel	Outputs separate				
Output 4 and 5 parallel	Outputs separate				
Output 6 and 7 parallel	Outputs separate				

MODBUS TCP interface description

3.9 Data word structure of the I/O modules

3.9.1 Analogue modules

Analogue signals are exchanged between the IS1 field station and an automation system in 16-bit two's complement format (signed integer, high byte first if using Register functions). Converting to and from floating point variables (physical values) must be performed in the automation system if required.

AIM, AIMH (9460/..., 9461/...)
0 – 20 mA

Measuring range 0 – 20 mA	Units		%	Parameter: Measurement range limits according NAMUR	Range	Alarms / Diagnostics
	Decimal	Hex				
>23.518 mA >21 mA	*1)	*1)		No Yes		Short circuit
23.518 mA 21 mA	32511 29030	7EFF 7166	117.6% 105 %	No Yes	Over range	-
20 mA 10 mA 0 mA < 0 mA	27648 13824 0 0	6C00 3600 0 0	100% 50% 0% 0%		Nominal range	-

AIM 4 – 20 mA

Measuring range 4 – 20 mA	Units		%	Parameter: Measurement range limits according NAMUR	Range	Alarms / Diagnostics
	Decimal	Hex				
>22.814 mA >21 mA	*1)	*1)		No Yes		Short circuit
22.814 mA 21 mA	32511 29376	7EFF 72C0	117.6% 106,25 %	No Yes	Over range	-
20 mA 12 mA 4 mA	27648 13824 0	6C00 3600 0	100% 50% 0%		Nominal range	-
3.999 mA 3,6 mA 2,4 mA	-1 -691 -2765	FFFF FD4D F533	-2,5% -10%	Yes No	Under range	-
< 3,6 mA < 2.4 mA	*1)	*1)		Yes No		Line break

*1) Transmitted value depends on behaviour set in the parameters if an error occurs:

Behaviour set in the parameters if an error occurs	Type of error	Value transmitted if an error occurs	
Freeze	All I/O module errors	Last valid value	
-10%	All I/O module errors	-2765	F533
0%	All I/O module errors	0	0
100%	All I/O module errors	27648	6C00
Alarm code	Short circuit	32767	7FFF
	Open circuit	-32762	8006
	I/O module does not respond	-32736	8020
	Config. unequal from module	-32735	8021
	Data not available	-32734	8022

General rule to generate status information in AS for all AI signals:
Signal has malfunction if value >= 32512 or value <= -32512
see 3.10.1 [Behaviour of the input signals in case of errors](#)

MODBUS TCP interface description

TIM (9480/... , 9481/...)

Temperature measurement (1 Digit = 0,1 °C)

Temperature	Units		Range	Alarms / Diagnostics
	Decimal	hexadecimal		
	*1)	*1)		Upper limit exceeded
*2) 1000 °C	*2) 10000	*2) 2710	Temperature measurement range	
1 °C	10	000A		
0 °C	0	0		
-0,1 °C	-1	FFFF		
-100 °C	-1000	FC18		
*2)	*2)	*2)		Lower limit exceeded
	*1)	*1)		

*2) The limits of the measurement range depend on the input type set in the parameters (see Operating instructions IS1)

2 wire and 4 wire resistance measurement 500 R 10K (module 9480 /)

Range				Units		%	Range	Alarms / Diagnostics
500 R	2 K 5	5 K	10 K	decimal	hexadecimal			
>588 R	>2,94 K	> 5,88K	>11,76 K	*1)	*1)			Line break
588 R	2,94 K	5,88 K	11,76 K	32511	7EFF	117,6%	Over range	-
500 R	2 K 5	5 K	10 K	27648	6C00	100%	Nominal range	-
250 R	1K250	2K5	5 K	13824	3600	50%		
0 K	0 K	0 K	0 K	0	0	0%		

3 wire resistance / position measurement 500 R 10K (module 9480/..)

Range				Units		%	Range	Alarms / Diagnostics
500R	2K5	5 K	10 K	decimal	hexadecimal			
>588 R	>2,94 K	>5,88 K	>11,76K	*1)	*1)			Line break
position 100 %				27648	6C00	100%	Nominal range	-
position 50 %				13824	3600	50%		
position 0 %				0	0	0%		
< 50 R	< 250 R	< 500 R	< 1 K	*1)	*1)			short circuit

0,02 R	0,1 R	0,2 R	0,4 R	Resolution per digit				
--------	-------	-------	-------	----------------------	--	--	--	--

MODBUS TCP interface description

0 ... 100 mV measurement (9481/..)

Range 0 ... 100 mV	Units		%	Range	Alarms / Diagnostics
	decimal	hexadecimal			
>117,6 mV	*1)	*1)			Upper limit exceeded
117,6 mV	32511	7EFF	117,6 %	Over range	-
100 mV	27648	6C00	100 %	Nominal range	-
50 mV	13824	3600	50 %		
0 mV	0	0	0 %		
-0,0036 mV	-1	FFFF		Under range	-
-10 mV	-2765	F533	-10 %		
< -10 mV	*1)	*1)			

Short circuit alarm cannot be detected during resistance and voltage measurement !

***1) Transmitted value depends on behaviour set in parameters if an error occurs:**

Behaviour set in parameters if an error occurs	Type of error	Value transmitted if an error occurs	
freeze	All I/O module errors	Last valid value	
Alarm code <small>General rule to generate status information in AS for all AI signals: Signal has a malfunction if value >= 32512 or value <= -32512 see 3.10.1 Behaviour of the input signals in case of errors</small>	Short circuit	+ / - 32767	7FFF / 8001
	Open circuit	+ / - 32762	7FFA / 8006
	Upper limit exceeded	32761	7FF9
	Lower limit exceeded	-32760	8008
	Cold Junction error	-32752	8010
	I/O module does not respond	-32736	8020
	Config. unequal from module	-32735	8021
	Data not available	-32734	8022
	I/O module hardware error	-32733	8023

*1) Depending on the direction of signal change, for the respective error type a positive or negative alarm-code is used:

Error type	TIM R 9480 / ...	TIM mV 9481 / ...
short circuit	-32767 (8001)	not detectable
open circuit	+32762 (7FFA)	-32762 (8006)

MODBUS TCP interface description

AOM 0 – 20 mA

Measuring range 0 – 20 mA	Units		%	Range
	Decimal	Hexadecimal		
*1)	>30137	>75B9		
21,8 mA	30137	75B9	109%	Over range
.	.	.		
20 mA	27648	6C00	100%	Nominal range
.	.	.		
10 mA	13824	3600	50%	
.	.	.		
0 mA	0	0	0%	
0 mA	< 0	< 0		

AOM 4 – 20 mA

Measuring range 4 – 20 mA	Units		%	Range
	Decimal	Hexadecimal		
*1)	>30759	>7827		
21,8 mA	30759	7827	111,25%	Over range
.	.	.		
20 mA	27648	6C00	100%	Nominal range
.	.	.		
12 mA	13824	3600	50%	
.	.	.		
4 mA	0	0	0%	
3,999 mA	-1	FFFF		Under range
0 mA	-6912	E500	-25%	
0 mA	< -6912	< E500		

*1): The AOM attempts to increase the current further according to the control value. However, depending on the load resistance, the maximum output voltage of the AOM may be reached, as a result the current can no longer be increased.

Safe setting after power on:

After CPU power on the data area for the outputs is initialised with the value -32768 (0x8000) as the code for the safe setting.

The outputs remain in the safe setting until the allocated register is overwritten with a valid output value (<> -32768 (0x8000)) by AS or by the IS1 DTMs.

3.9.2 DIM, DIM+CF (9470/.. 9471/..)

On the modules 9470 und 9471 the inputs 14 und 15 can optionally be used as a digital input (DI), counter input (C) or frequency input (F).

MODBUS TCP interface description

The operating mode for the DIM can be selected in the IS1 DTMs.

Operating mode selection	Input data	Output data	Available signal types for inputs 14 and 15
DIM 16 (9470/.. , 9471/..)	2 bytes (16 bit DI)	-	Only DI (without status)
9470 /.. -16-1. DIM 16 9471 /.. -16-1. DIM 16	4 bytes (16 bit DI + 16 bit status)	-	Only DI (with status)
9470 /.. -16-1. DIM 16+CF 9471 /.. -16-1. DIM 16+CF	8 bytes (16 bit DI + 16 bit status + 2 words CF)	1 byte (control register for counter)	DI or counter or frequency (with status)

Even if DIM 16+CF (with counter / frequency) is selected the inputs 14 and 15 are updated in the DI data area and can therefore also be used as DI signals in this operating mode.

Data word structure DI (inputs I0 to I15)

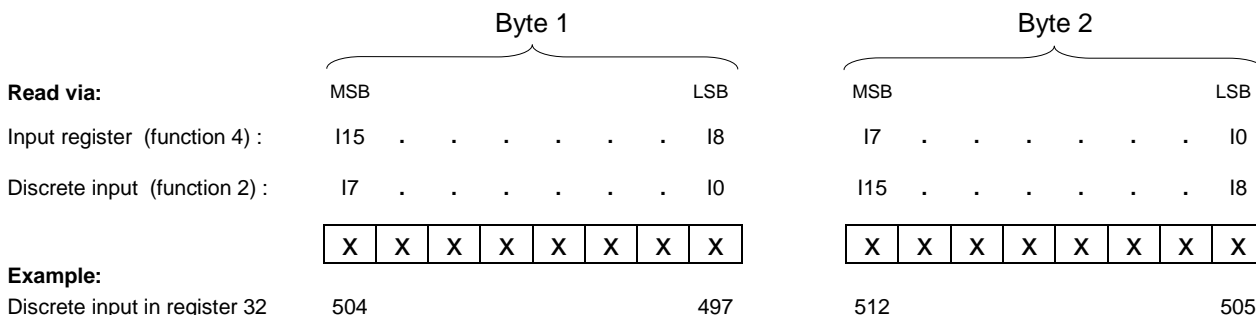

Signal definition with parameter 'Invert all inputs of the module = No':

Module	Open circuit alarm	Signal = 0	Signal = 1	Short circuit alarm
9470/ ...	I < 0,05 mA	I < 1,2 mA	I > 2,1 mA	R _L < 100 Ohm
9471/ ...	-	U < 5 V	U > 13 V	-

Attention !

In case of upgrades of IS1 field stations with MODBUS RTU via RS485 to IS1 with MODBUS TCP please note, that the high byte and low byte is swapped for DI signal and status registers.

MODBUS TCP interface description

Data word structure status (status bits S0 to S15)

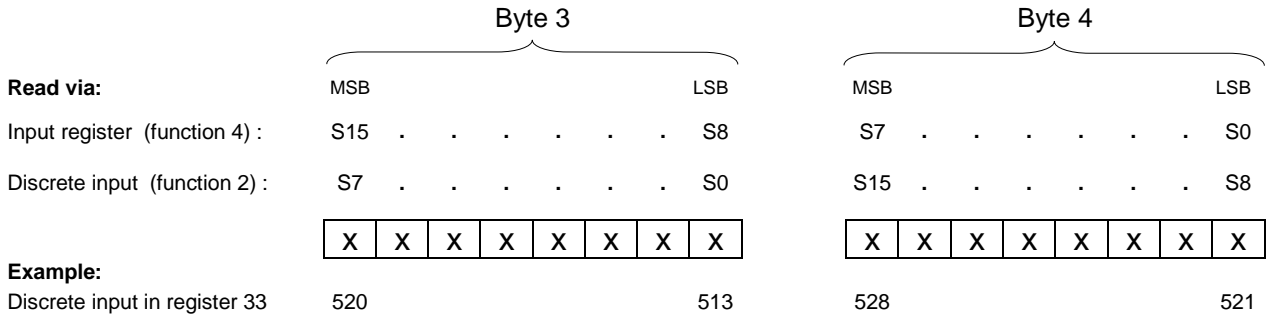

Status bit = 1: Signal OK
 Status bit = 0: Signal malfunction

Signal and status are transmitted synchronously and consistently!

Data word structure (DIM 16 with status)

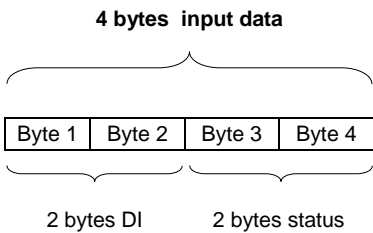

Data word structure (DIM 16+CF)

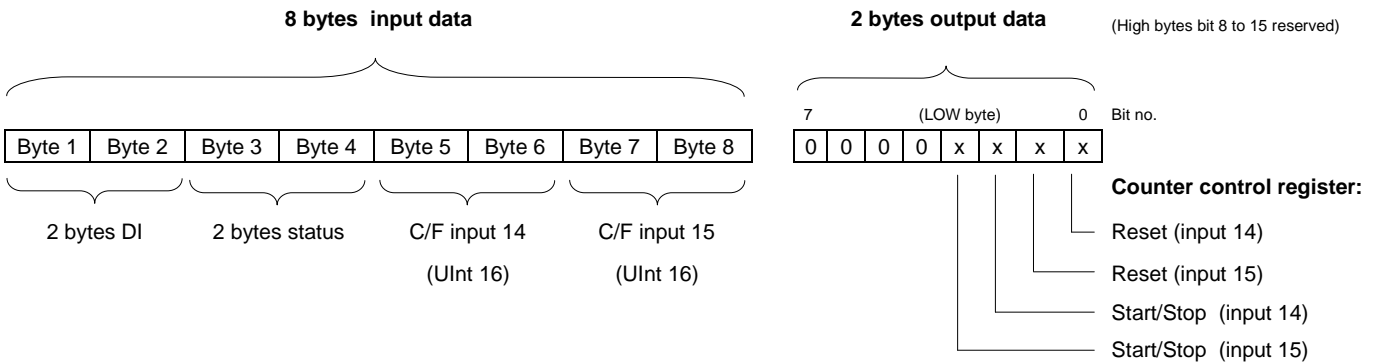

Reset = "0": counter running	Start/Stop = 0 : counter running
Reset = "1": counter = 0	Start/Stop = 1 : counter stopped

MODBUS TCP interface description

Operating mode 'counter'

Incremental operation with overflow (after 65535 register changes to 0)

Count range:	0 – 65535 (Unsigned Integer UInt16)
Count event:	Positive / negative edge selectable.
Signal in case of error:	Freeze last value (Initial value 0)
Alarming:	Status and channel diagnosis
Reset:	Reset counter register to '0'
Start/Stop:	In 'Stop' mode input pulses are ignored (not counted)

Status in operating mode 'counter':

The status is initialised with '0' = signal malfunction.

Using the Reset bit in the control register, the counter register is set to '0' and the status is set to '1' = signal OK.

In case of errors (short circuit, open circuit) the status is set to '0' and will be held at '0' until the next reset. Therefore malfunctions during the count procedure are recognisable via the status.

Operating mode 'Frequency'

Selection operation mode:	Measurement method	Scaling	Resolution
Frequency 1 Hz -1 kHz	Pulse time measurement	0,05 Hz / Bit	+/- 0,05 Hz
Frequency 0-20 kHz gate time 50 ms	Gate time measurement	1 Hz / Bit	+/- 20 Hz
Frequency 0-20 kHz gate time 200 ms	Gate time measurement	1 Hz / Bit	+/- 5 Hz
Frequency 0-20 kHz gate time 1 s	Gate time measurement	1 Hz / Bit	+/- 1 Hz

Measuring range 1 Hz – 1 kHz	Measuring range 0 – 20 kHz	Units		%	Range
		decimal	hex		
1,3 kHz	-	26000	6590	130 %	Over range
1,1 kHz	22 kHz	22000	55F0	110 %	
1 kHz	20 kHz	20000	4E20	100 %	Nominal range
500 Hz	10 kHz	10000	2710	50 %	
0 Hz	0 kHz	0	0	0 %	

Signal in case of error:	Freeze (Initial value 0)
Alarming:	Status

Behaviour in case of excessively high frequencies:

If the input frequency is higher than the maximum over-range value allowed, input pulses can no longer be detected. Pulses are lost during the evaluation and as a result the measured value is smaller than the frequency actually present at the input. No alarm is generated.

MODBUS TCP interface description

3.9.3 DOM (9475/..., 9476/..., 9477/..)

Data word structure DO (Outputs O0 to O7)

DOM 8 channels:

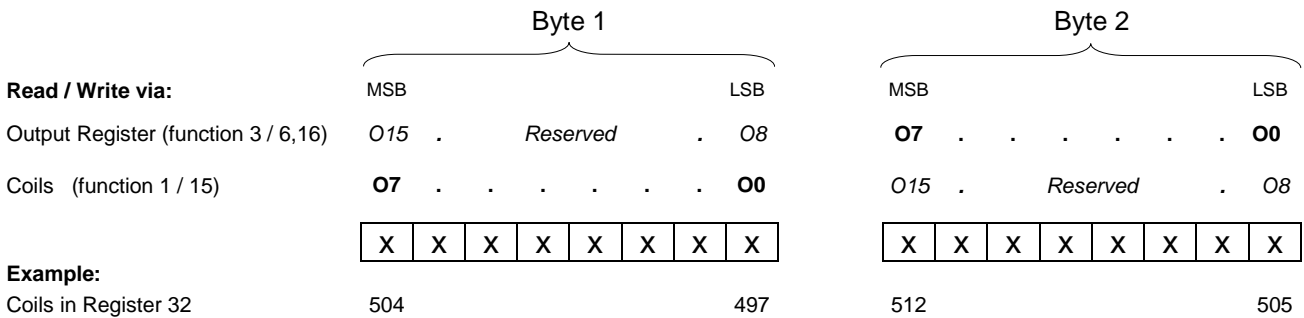

Register format: **High byte first**

All DO data are in the low byte of the register. The high byte is reserved.

DOM 4:

The bits 4 to 7 for the outputs for 4 to 7 are not used (= 0).
All other outputs are allocated as shown above.

Signal definition:

signal bit = 0	signal bit = 1	Type
output high impedance (actuator = Off)	output is powered according type specification (actuator = On)	DOM
relay contact = open	relay contact = closed	DOMR
Valve closed	Valve open	DOMV

MODBUS TCP interface description

3.10 Signal behaviour in case of errors

3.10.1 Behaviour of the input signals in case of errors

If no valid signal value can be formed as a result of a malfunction (short circuit, open circuit, defective subassembly...), an item of diagnostics information is created which can be read via the IS1 DTMs. Despite the outstanding malfunction, data continues to be transmitted to the AS.

The behaviour of the signal values transmitted if a malfunction has occurred can be selected separately for every module by setting parameters (see 3.8.2 [I/O module parameters](#)).

Application hint:

If the behaviour of input signals in case of errors is realised through the IS1 system, this behaviour seen from the application software in the automation system can only be guaranteed with correct communication on MODBUS.

In the event of the failure of the MODBUS additional project specific reactions must be realised in the application software.

To guarantee the same behaviour of all input signals in the event of an error, we recommend the following procedure:

Generate a status bit for each input signal in the automation system:

- for DI signals the status bits available optionally from IS1 are used in the input data area.
- for AI signals the 'Alarm code' behaviour parameter are set in the IS1. In the application software the following function must be used:

```

If SignalValue >= 32512 Or SignalValue <= -32512 then
    SignalStatusBit = disturbed
Else
    SignalStatusBit = OK
End IF
    
```

The signal behaviour in case of an error (freeze, substitute value ...) can now be realised in the automation system controlled by the related status bit.

In this case the event 'Slave failure on MODBUS' can be logical linked to the signal status whereby the signal behaviour in case of an error is always the same under all error conditions.

To generate alarm messages for output modules, in the automation system one bit per module (module alarm bit) can be polled by the CPU to generate messages. The details on the diagnostics information should be read and displayed via the IS1 DTMs.

MODBUS TCP interface description

3.10.2 Behaviour of the output signals in case of errors

Communication error between the master and IS1 field station:

The cyclic data traffic between the MODBUS TCP client and IS1 is checked using response monitoring in the IS1 CPU.

Response monitoring in the CPU makes sure that if the master suffers a failure or there is some other communication loss to the master after expiry of the time (T_{WD}), all output registers are set to 0x8000H and the outputs adopt the safe state. The allocated Ethernet connection will be closed and is then enabled for use for other MODBUS clients.

The T_{WD} (Watchdogtime AS interface) time parameter can be set in the range 100 ms to 25.5 seconds ,(default = 2 sec.).

The response monitoring of the slaves can also be deactivated ($T_{WD}=0$). In this case, a loss of communication to the master cannot be recognised. The output signals from the field stations are frozen if updating from the master cannot be performed.

Communication error between the CPU and output module:

There are watchdog circuits on the output modules that monitor the data transmission between the CPU and the output modules. If an output module does not receive any valid data for more than T_{Mod} , the subassembly adopts the safe setting.

T_{Mod} (timeout for output modules) parameter can be set in the range 100 ms to 25.5 sec. (default value: 100 ms).

Consequently, the safe setting for the output modules follows at a delay of T_S after failure of the communication to the master where:

$$T_S = T_{WD} + T_{Mod}$$

Application Hint:

In unstable Ethernet Networks short interruptions of Modbus connections with automatic restart of the connections may occur with the result, that IS1 output signals go to safe position during such disturbances of communication. Network wiring and communication quality shall be checked and improved in such cases.

To improve robustness of the output signals against such short communication interruptions the parameter 'communication timeout for output modules' T_{Mod} should be set:

$$T_{Mod} > \text{Max. AS Update cycle for writing output data} + 10\%$$

Output signals will be frozen during the disturbances with this setting.

The safe setting parameter for the output signals can be set separately for each module (see 3.8.2 [IOM Parameter](#)).

MODBUS TCP interface description

3.11 HART variables

In addition to the analogue process value, HART field devices offer the option of digitally reading up to four process variables (HART variables HV) from the transmitter.

IS1 offers the option of mapping such HART variables to MODBUS registers.

HART variables can be read from the primary or the backup CPU.

Optionally, no HART variables, four or eight HART variables from an IS1 HART module (AIMH, AOMH) can be transmitted in addition to the cyclic data.

This can be selected optionally when configuring a field station via the IS1 DTMs:

3.11.1 Module selection in IS1 DTM

Module selection text	Length cyclic data [bytes]		Number of HART variables (HVs) transmitted
	Input	Output	
9461/12-08-11 AIMH8 2w Exi	16	0	None
9461/12-08-11 AIMH8+4HV 2w Exi	32	0	4 HV
9461/12-08-11 AIMH8+8HV 2w Exi	48	0	8 HV
9461/12-08-21 AIMH8 Exi	16	0	None
9461/12-08-21 AIMH8+4HV Exi	32	0	4 HV
9461/12-08-21 AIMH8+8HV Exi	48	0	8 HV
9466/12-08-11 AOMH8 Exi	0	16	None
9466/12-08-11 AOMH8+4HV Exi	16	16	4 HV
9466/12-08-11 AOMH8+8HV Exi	32	16	8 HV

3.11.2 Data format

HART variables are transmitted as IEEE floating-point numbers (4 bytes).

If a HART variable cannot be read (e.g. HART device undergoing startup, not connected, defective or HART variable not found, ...), value 7F A0 00 00 (Not a Number) is transmitted. This may be evaluated in the AS for generation of a signal status of the HART variables. Detailed status and diagnostic information on the HART field devices can be evaluated via HART Management Systems.

MODBUS TCP interface description

3.11.3 Data structure

Example: AIMH

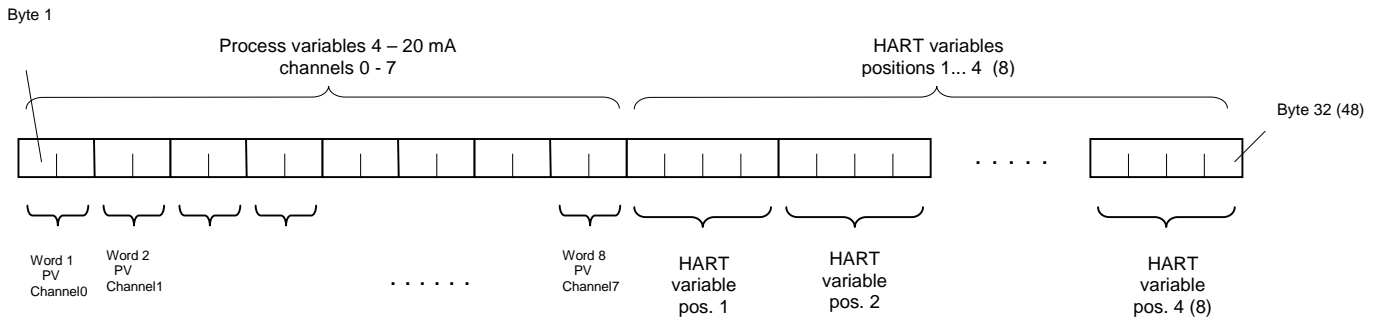

Example: AOMH

Input data:

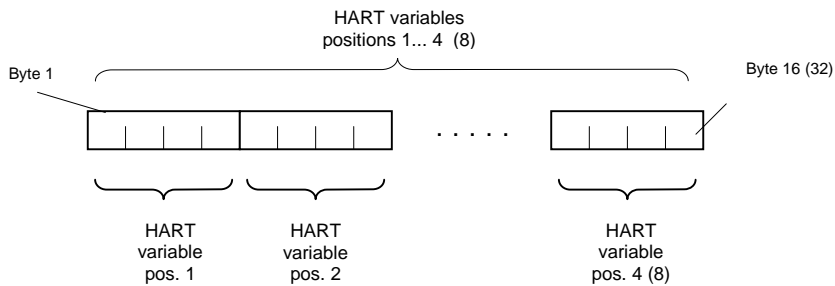

Output data:

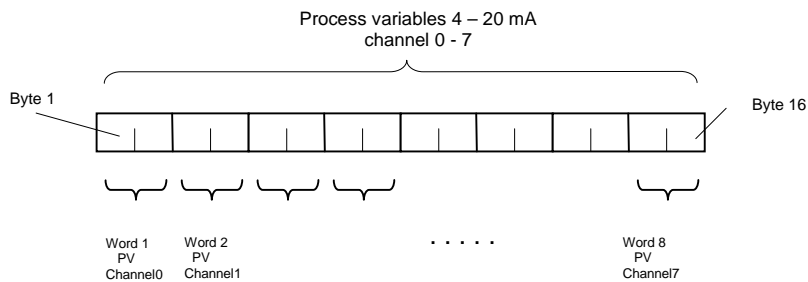

MODBUS TCP interface description

3.11.4 Selection of HART Variables

Up to 8 HART field devices can be connected to one HART module of IS1. Since each HART field device may have up to 4 variables, this mean that a maximum of 32 HART variables are possible per module. The assignment of 4 or 8 out of these 32 variables to the positions in the cyclic transmission area can be selected by parameter assignment:

Parameter name	Value range	Function
Input No. HART device for pos. 1	0 ... 7, Not used	Selection of the channel no. (input / output no.) of the HART module to which the HART field device is connected which is to be transmitted at pos. 1. If 'Not Used' is selected, value 'Not a Number' (7F A0 00 00) is transmitted.
Input No. HART device for pos. 2	0 ... 7, Not used	Selection for pos. 2
.....		
Input No. HART device for pos. 4 (8)	0 ... 7, Not used	Selection for pos. 4 (8)
No. HART variable for pos. 1	1 ... 4	Selection of the variables of the HART field device which is to be transmitted at pos. 1.
No. HART variable for pos. 2	1 ... 4	Selection for pos. 2
.....		
No. HART variable for pos. 4 (8)	1 ... 4	Selection for pos. 4 (8)

3.11.5 HART Livelist

Overview of the status of all HART field devices connected to one IS1 field station for simplified commissioning and maintenance.

For further information for use of the IS1 DTMs see operating instructions 'DTM IS1 Mod'.

MODBUS TCP interface description

3.12 IS1 DTMs

Configuration, parameter setting, diagnostics and HART communication for the IS1 field stations is handled via the IS1 DTMs using FDT technology.

Example: Signals / Diagnostics

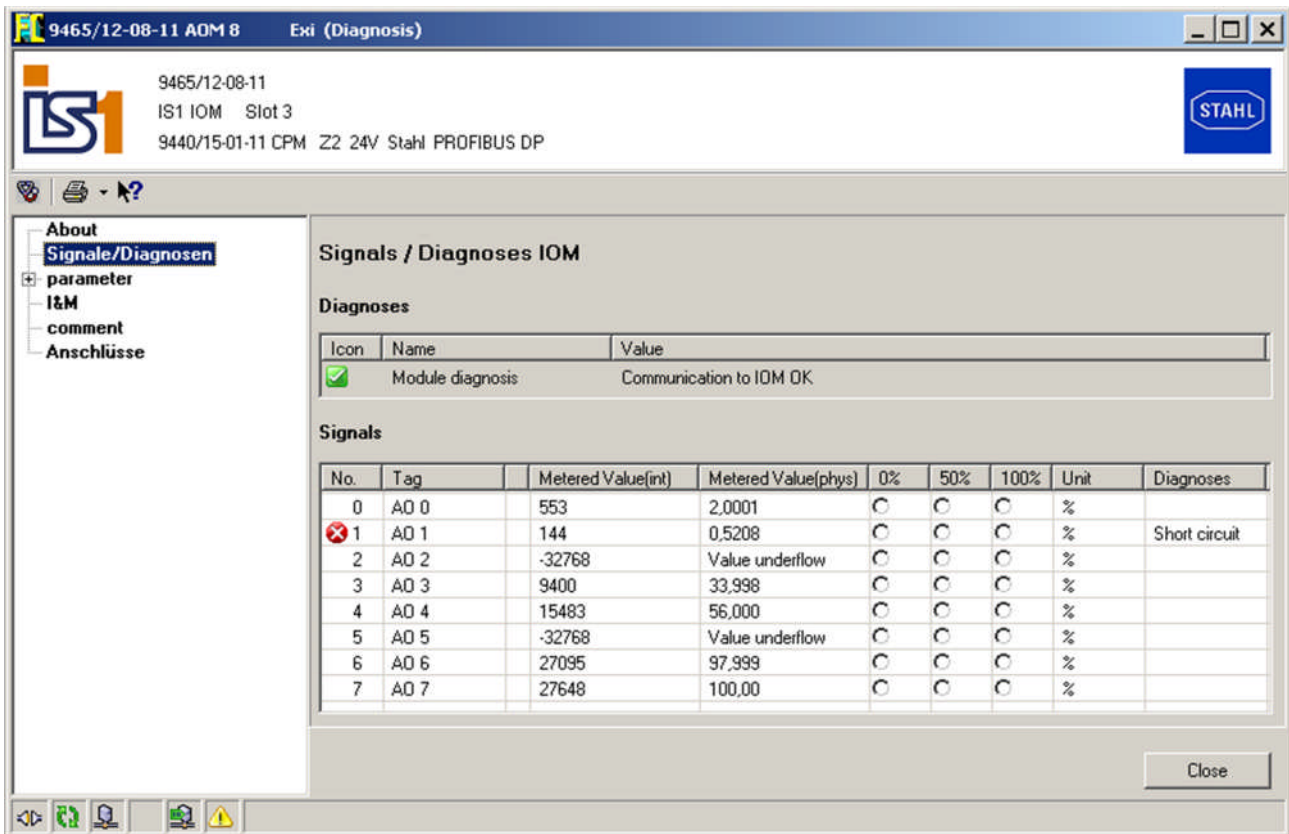

For further information on the use of the IS1 DTMs see operating instructions 'DTM IS1 Mod'.

MODBUS TCP interface description

3.13 Webserver in IS1 CPU

A webserver is integrated in the IS1 CPUs which offers additional diagnostic functions for commissioning, maintenance and OEM service support.

For access standard WEB browsers (e.g. Microsoft Internet Explorer) can be used.

Example: MODBUS

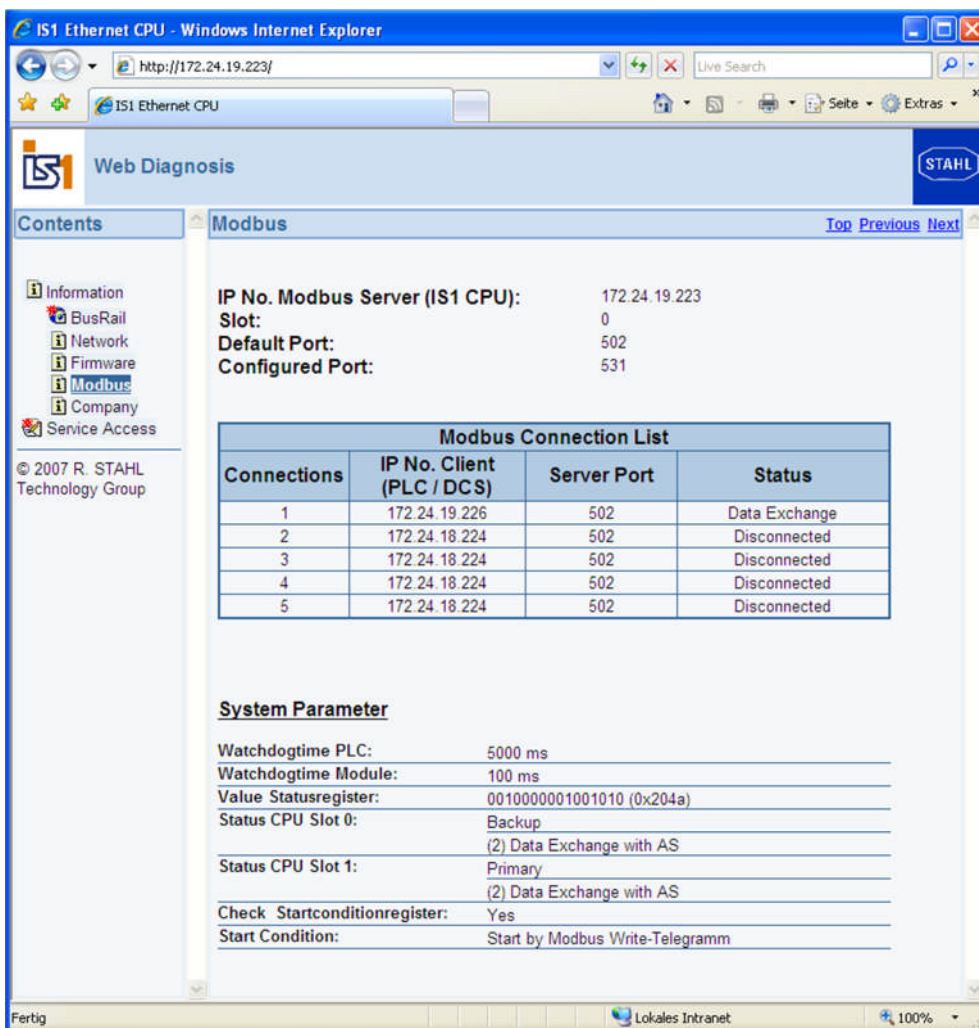

Status	Description
Data Exchange	Connection is in cyclic data exchange and is monitored for timeout. (see Parameter ' Watchdogtime AS Interface T _{WD} ')
Disconnected	Timeout T _{WD} for connection elapsed. Connection not actually in use. The IP address and port no. of the last connected client is displayed.
not used	Connection has not been used since CPU power on.

MODBUS TCP interface description

3.14 LED and LCD displays of the CPU

The operational state and the communication on the MODBUS can be assessed on site using the LEDs and the LCD display on the CPU of an IS1 field station. Additionally the signal values, the signal and module alarms can be displayed on the LCD display.

For details, see the IS1 operating instructions.

MODBUS TCP interface description

3.15 Online behaviour of the IS1 field station.

3.15.1 Parameter changes.

If an IS1 field station is exchanging data with the MODBUS master, parameters can be modified in operation (online) via the IS1 DTMs.

Exception: CPU parameter 'Watchdogtime AS Interface T_{WD} ' and 'Alternative MODBUS Port'
see [CPU parameters](#)

3.15.2 Configuration changes.

If an IS1 field station is exchanging data with the MODBUS master, new or modified configuration data can be loaded to the CPU using the IS1 DTMs.

The mapping of the I/O signals to the MODBUS registers is according the new configuration. It is therefore to be checked, whether, due to the configuration changes, adjustments in the signal mapping in the automation system are necessary.

The restarted CPU checks the real existing modules (actual state) against the configuration data (target state).

All modules of the field station where the configured modules agree with the existing module type in the field station are updated cyclically after start-up.

For modules, which do not agree with the configuration data, alarms are generated. The signals for these modules are not updated and react according the behaviour set in the parameters in case of error.

Due to the behaviour described above, a field station can be expanded online by adding new modules to the existing modules. In this case the assignment of the signals for the existing modules in the field station to the MODBUS registers is not changed.

Newly added modules are appended to the end of the register area used previously.

Process for online expansion:

- Add new modules (expansions to an existing field station) in free slots on the rail **after** the existing I/O modules.
- Add new modules to configuration offline in FDT frame.
- Online download of the configuration to the CPU while MODBUS is running.
- Expansion of the current messages in the MODBUS TCP master with the signals for the newly added modules.

Attention!

An **online change is not possible** if existing modules are changed for other module types and as a result the number of input and output registers at the module slot to be processed changes.

In this case the mapping in the automation system must be modified which is usually not possible without effects on the running process.

MODBUS TCP interface description

3.16 Transmission time:

Total delay of input signals (worst case):

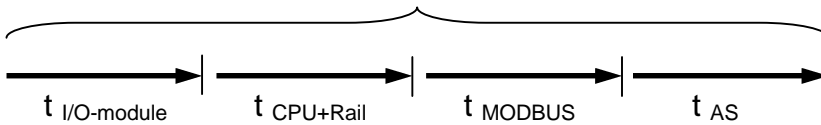

Total delay of output signals (worst case):

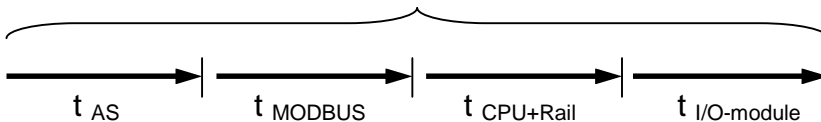

$t_{I/O\text{-module}}$ max. signal delay see operation manual of the different IS1 I/O modules.

$t_{CPU+Rail}$ ca. 4ms + number IOM * 1 ms (from Firmware V21-09)

t_{MODBUS}	Data Length	1 Register	100 Register	200 Register	16 Coils	800 Coils	1600 Coils
Delay *1)		1,5 ms	2 ms	2,5 ms	1,7 ms	2,6 ms	3,5 ms

*1) typical delay between Request and Response telegram inside of a switched network. Using access via Routers or Internet the value will increase.

t_{AS} AS cycle + further delays in automation system (AS)

4 List of abbreviations:

AS	A utomation S ystem
AIM	A nalogue I nput M odule
AIMH	A nalogue I nput M odule + H ART
SAIMH	S afety A nalogue I nput M odule + H ART (PROFIsafe)
AOM	A nalogue O utput M odule
AOMH	Analogue Output Module +HART
CPM	C PU + P M = CPM Central unit consisting of communication processor with power pack
DIM	D igital I nput M odule
DOM	D igital O utput M odule
DOMR	D igital O utput M odule R elays
DOMV	D igital O utput M odule V alves
HW	Hardware
IOP	I/O Processor of the central unit
IOM	General description of I/O Module
PM	P ower M odule (power pack)
SW	Software
SIL	S afety I ntegrity L evel
TIM	T emperature I nput M odule

MODBUS TCP interface description

5 Release notes:

Version Interface description MODBUS TCP	Extensions / Changes
V 1.00	First official release
V1.05	IS1 CPU Redundancy with redundant MODBUS TCP Networks supported.
V1.06	DOMV 9478/22-08-51 supported.
V1.07	From firmware rev. 21-09: <ul style="list-style-type: none"> • Read Input Data optional via MODBUS function 3 with register offset +1000 • Railcommunication timing optimized • Support of read output data from backup CPU with DTM. • Status display of backup CPU in DTM – bugfix.
V1.08	<ul style="list-style-type: none"> • 9480 TIMR Parameters added for CU53 GOST, Pt46 GOST, Pt50 GOST
V1.09	From Firmware 21-11: <ul style="list-style-type: none"> - BootP – IP address setting via BootP Server - ACD Address Conflict Detection
V1.10	Description extended for start condition in case of redundant CPUs
V1.11	Application Hint added in chapter 3.10.2

6 Further reading

- [MODBUS MESSAGING ON TCP/IP IMPLEMENTATION GUIDE V1.0b](#)
- [MODBUS APPLICATION PROTOCOL SPECIFICATION V1.1b](#)

Available at: <http://www.MODBUS.org/> -> Technical Resources -> MODBUS Specifications

7 Support address

R. Stahl Schaltgeraete GmbH

Center of Competence Instrumentation Systems

eMail: support.instrumentation@stahl.de

Support information: <http://www.stahl.de>

Service hotline IS1: +49 (7942) 943-4123

Fax : +49 (7942) 943-40 4123