

## 5 ENGINEERING

### 5.1 Safety instructions for system configuration and explosion protection

	<p>During engineering, comply with the guidelines set out in EN 60 079-14. The conditions required in the standard for electrical parameters are summarized for simple circuits in <i>Tab. 5-2</i>.</p>
---	---

#### 5.1.1 Zone-specific conditions for system configuration

Zone 1	Zone 2	Safe area
Engineering to Ex i for field circuits		
<ul style="list-style-type: none"> <li>• Enclosure EEx e</li> <li>• CPU &amp; Power Module for Zone 1</li> <li>• Power supply in Ex e technology</li> <li>• Fieldbuses intrinsically safe to Ex i</li> <li>• Fieldbus isolating repeater (must be installed in safe area)</li> </ul>	<ul style="list-style-type: none"> <li>• Enclosure IP 54 with manufacturer declaration for Zone 2 (in compliance with EN 50021: Protection against mechanical damage; protection class IP 54; prevention of ignition dangers through electrostatic charges, permissible ambient temperature in normal operation)</li> <li>• Other electrical components to at least Ex n in compliance with EN 50021</li> </ul>	Enclosures IP 20

**Tab. 5-1** Zone-specific conditions for system configuration

#### Additional zone-specific requirements

	<p>See <i>Tab. 5-3</i>: Zone and protocol specific requirements for isolating repeaters and the number of field stations.</p>
---	---

# OPERATING INSTRUCTIONS FOR THE I.S. 1 SYSTEM

## 5.1.2 Maximum values of field devices and field circuits regarding intrinsic safety

 <b>Warning</b>	<p><b>ENDANGERING OF INTRINSIC SAFETY!</b></p> <p>The connection of an intrinsically safe field device with an intrinsically safe input or output must result in an intrinsically safe circuit! Therefore:</p> <ul style="list-style-type: none"> <li>➤ When selecting the field devices to be connected with the I/O modules, check the resulting safe values!</li> <li>➤ Take into account the inductance and capacitance of the cable!</li> </ul>
---	--

### Further information regarding fieldbuses in Zone 1

	<p>See Chapter 4.3.3 (Isolating repeaters and number of field stations).</p>
---	--

### Proof of intrinsic safety

The proof of intrinsic safety must be implemented for each field circuit in compliance with the regulations specified by the applicable standards for engineering, selection and installation.

A basic, intrinsically safe circuit is created by the connection of a field device to the input or output of an I/O module.

Tab. 5-2 shows the conditions for the testing of safe maximum values for a basic, intrinsically safe circuit:

Necessary standards/ conditions for electrical parameters	Engineering information for field station
<p>Standard: EN 60 079-14</p> <p>The following applies for the electrical parameters:</p> <ul style="list-style-type: none"> <li>• <math>U_o \leq U_i</math></li> <li>• <math>I_o \leq I_i</math></li> <li>• <math>P_o \leq P_i</math></li> <li>• <math>C_o \geq C_i + C_{cable}</math></li> <li>• <math>L_o \geq L_i + L_{cable}</math></li> </ul>	<ul style="list-style-type: none"> <li>• The safe maximum values for the field devices must be matched to the corresponding maximum values of the I/O module.</li> </ul> <p>These maximum values can be found in the Ex certificates of the field devices or the I/O module.</p>

**Tab. 5-2** Maximum values of the field devices and field circuits

## 5.1.3 Maximum system configuration in Zone 1

 <b>Warning</b>	<p><b>SYSTEM LIMITS</b></p> <ul style="list-style-type: none"> <li>➤ In Zone 1 a field station may be extended to a maximum of 8 I/O modules.</li> </ul>
---	--

## 5.1.4 Usage of isolating repeaters

 <b>Warning</b>	<p><b>LASER RADIATION!</b></p> <p>Laser radiation can be emitted from fieldbus isolating repeaters for fibre optic cables! Looking directly at the laser beam can cause eye injuries.</p> <ul style="list-style-type: none"> <li>➤ Never look directly into the laser beam!</li> </ul>
---	--

 <b>Warning</b>	<p><b>ENDANGERING OF INTRINSIC SAFETY!</b></p> <p>The fieldbus is not intrinsically safe without special measures.</p> <ul style="list-style-type: none"> <li>➤ Fieldbus isolating repeaters must be used in Zone 1!</li> </ul>
---	---

As an off-the-shelf explosion protected mounted unit, the I.S. 1 field station can be installed directly in the hazardous area (Zone 1).

The fieldbus isolating repeater for the fieldbus takes on the function of a barrier between the Ex area and non-Ex area relating to explosion protection. The fieldbus isolating repeater operates as a repeater.

### Isolating repeater

The available types are:

- Fieldbus isolating repeater RS 485 for copper cables
- Fieldbus isolating repeater for fibre optic cables

	<p>See Chapter 14.2 for information regarding additional accessories and isolating repeaters.</p>
---	---

## 5.2 Overall engineering of I.S. 1 systems

The following must be determined for the overall engineering of an I.S. 1 system:

- Type of communication protocol
- Application zone of the system
- Redundancy stages of the system
- Equipping a field station with I/O modules
- Engineering of the BusRail lengths
- Accessories and software

### 5.2.1 Components and software



See Chapter 4.6 (Description of components), Chapter 7.6 (Connection allocation of I/O modules), Chapter 13.3 (Technical data) and Chapter 4.3.5 (System software).

## 5.2.2 Communication protocols

### Profibus DP

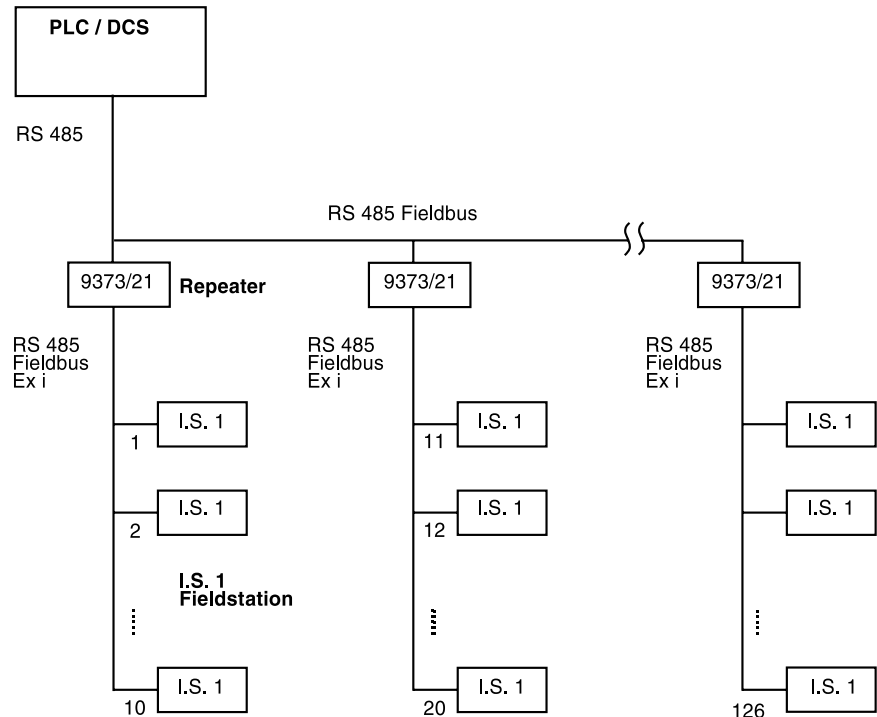

**Fig. 5-1** Fieldbus topology when using the Profibus DP

### Summary – Profibus

- A maximum of 126 field stations can be connected to a Profibus
- The Profibus master can lead to limitations in the maximum value:
  - Slaves which can be connected
  - The total number of I/O points
  - The I/O points per slave
- The CPU & Power Module supports a maximum of 16 or 8 I/O modules
- The CPU & Power Module currently supports a maximum of 112 bytes of input data and 80 bytes of output data; an increase is in preparation
- The fieldbus cable redundancy must be supported by the Profibus master (individual case examination)
- For additional details, see I.S. 1 operating instructions "Profibus DP coupling description"

### Modbus

- In preparation

### Speed / segment length

- Up to 93.75 kBit / s: 1,200 m
- 187.5 kBit / s: 1,000 m
- 500 kBit / s: 400 m
- 1500 kBit / s: 200 m

# OPERATING INSTRUCTIONS FOR THE I.S. 1 SYSTEM

## ServiceBus with PC Software "I.S. Wizard"

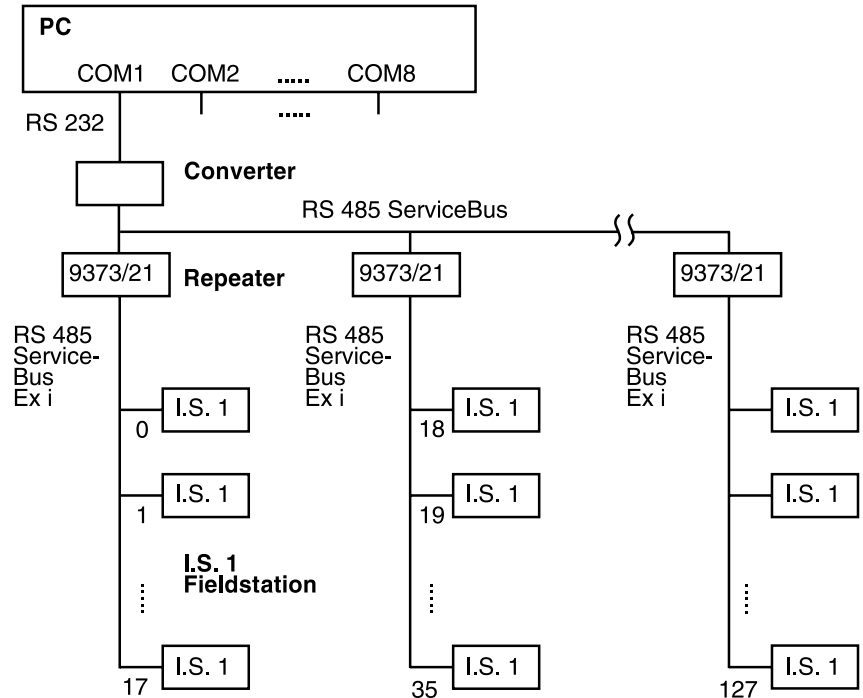
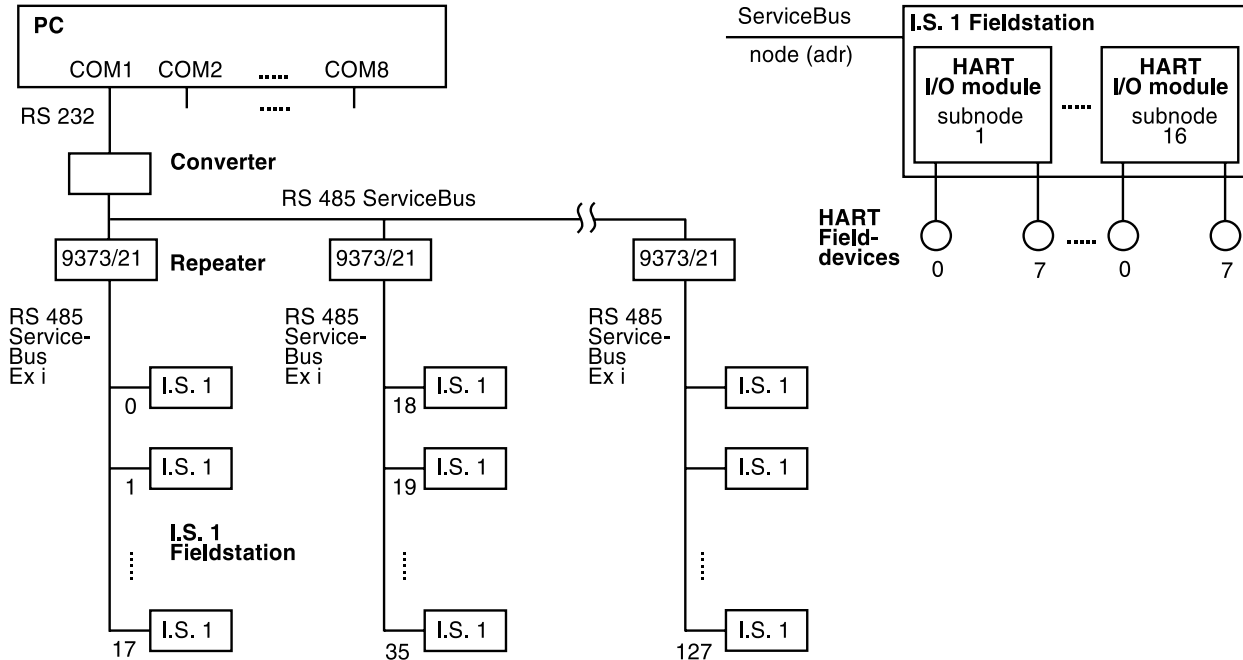

Fig. 5-2 Service-Bus topology when using the "I.S. Wizard"

### Summary – ServiceBus with PC Software "I.S. Wizard"

- A maximum of 128 field stations can be connected via a COM interface (i.e. to a ServiceBus). Limitations can result from the respective fieldbus used
- The "I.S. 1 Wizard" PC software supports a maximum of 8 ServiceBus interfaces with the COM 1..8 ports of the PC
- The address of a field station at the ServiceBus is identical to the address at the fieldbus

## ServiceBus with PC Software HART



**Fig. 5-3** Service-Bus topology when using the HART PC software

### Summary – ServiceBus with PC Software HART

- Cornerstone supports 8 ServiceBus interfaces on COM 1..8 and a maximum of 8000 HART field devices
- A maximum of 128 field stations can be connected via a COM interface (i.e. to a ServiceBus). Limitations can result from the respective fieldbus used
- The address of a field station at the ServiceBus is identical to the address at the fieldbus
- The maximum number of I/O modules in a field station is 16
- A maximum of 8 HART field devices can be connected to each HART I/O module
- HART Multidrop operation is not possible

# OPERATING INSTRUCTIONS FOR THE I.S. 1 SYSTEM

## 5.2.3 Zone-specific components / restrictions

Application zone and interface	Summary of the auxiliary components / restrictions	
	Maximum number of connectable field stations	
	With Modbus (up to 38.4 kBit / s)	With Profibus DP (up to 1.5 MBit / s)
Zone 1, fieldbus and redundant fieldbus segment	<ul style="list-style-type: none"> <li>• Maximum 18 field stations</li> <li>• With isolating repeater 9373/11 or isolating repeater 9373/21</li> </ul>	<ul style="list-style-type: none"> <li>• Maximum of 10 field stations</li> <li>• With isolating repeater 9373/21</li> </ul>
Zone 1, ServiceBus segment	<ul style="list-style-type: none"> <li>• Maximum of 18 field stations</li> <li>• With isolating repeater 9373/11 or isolating repeater 9373/21</li> </ul>	
Zone 2 or safe area for fieldbus, redundant fieldbus and ServiceBus segment	<ul style="list-style-type: none"> <li>• Maximum of 31 field stations</li> <li>• Isolating repeaters are not required</li> </ul>	

**Tab. 5-3** Zone and protocol specific requirements for isolating repeaters and the number of field stations

## 5.2.4 System engineering addresses

Designation in the I.S. 1 system	Other designations (e.g. with HART)	Address range
Fieldbus addresses (FB-Adr) = ServiceBus addresses	Node, slave	0 .. 127
I/O module number (Mod-No) = slot for I/O module	Sub node	1 .. 16
Channel number	Loop	0 .. 7 (with HART I/O modules) or 0 .. 4 / 8 / 16 (with other I/O modules)

**Tab. 5-4** Possible values of fieldbus addresses of the components of the I.S. 1 system and their designation

## 5.2.5 Engineering of the field stations (fitting)

Engineering information for fitting	Summary
Number and sequence of modules	<ul style="list-style-type: none"> <li>• The fitting of the BusRail begins with the CPU &amp; Power Module or with CPM primary + CPM redundant; the I/O modules follow after it</li> <li>• The maximum number of I/O modules per field station is 16 or 8 (look out for restrictions, e.g. through Profibus!)</li> </ul>
Engineering for Zone 2 or safe area	<ul style="list-style-type: none"> <li>• With installation in the safe area, the protection class IP 20 must be guaranteed</li> <li>• The enclosures for Zone 2 must have at least protection class IP 54 and be suitable for use in Zone 2 (manufacturer declaration)</li> <li>• The CPU &amp; Power Module supplies power for a maximum of 16 I/O modules</li> <li>• A redundant power supply input is feasible</li> <li>• I/O modules with Ex i and non-Ex i (in preparation) inputs/outputs can be mixed; if Ex i and non-Ex i modules are built in directly adjacent to one another, a partition (see accessories) is required</li> </ul>
Engineering for Zone 1	<ul style="list-style-type: none"> <li>• The enclosure must be EEx e certified or comply with the EEx e specifications</li> <li>• The CPU &amp; Power Module specifically suited to Zone 1 must be installed</li> <li>• The CPU &amp; Power Module supplies power for a maximum of 8 I/O modules</li> <li>• A redundant power supply input is feasible; a small EEx d enclosure is required for the installation of the decoupling diodes</li> <li>• Because of the additional socket, the CPU &amp; Power Module for Zone 1 requires more space</li> </ul>

Tab. 5-5 Engineering of the field stations (fitting)

 <b>Warning</b>	<p><b>FUNCTIONAL FAULTS AT INCORRECT FITTING!</b></p> <p>Fitting the I.S. 1 system upside down or lying on its side is not permissible.</p> <p>➤ I.S. 1 system modules must only be installed horizontally or vertically.</p>
---	---

# OPERATING INSTRUCTIONS FOR THE I.S. 1 SYSTEM

## 5.3 BusRail engineering

### 5.3.1 Tabular overview of the BusRail types

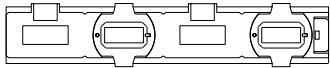
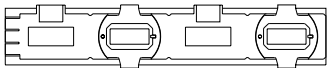
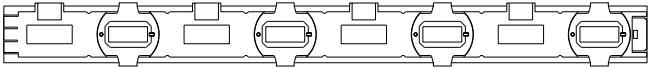
BusRail types	Abbreviation	Drawing
BusRail "begin" for 2 modules. The BusRail can be extended to the right.	BRB2	
BusRail "end" for 2 modules. The BusRail can be extended to the left.	BRE2	
BusRail "middle" for 4 modules. The BusRail can be extended to the right and left.	BRM4	

Tab. 5-6 BusRail types

### 5.3.2 Tabular overview of the terminations

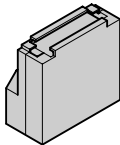
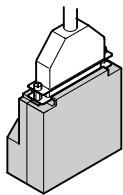
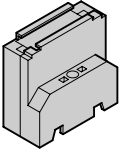
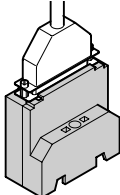
Terminations for the BusRail, description and graphics			
Termination "begin". Mechanical termination of the BusRail.	Termination "begin Sub-D". Mechanical termination and interface to a further rail.	Termination "end". Mechanical termination of the BusRail.	Termination "end Sub-D". Mechanical termination and interface to a further rail.
			

Tab. 5-7 Termination types

## 5.3.3 1st configuration alternative for the BusRail – on one rail

### Configuration on a rail

	<p>The permissible BusRail combinations shown in table <i>Tab. 5-8</i> can be built onto a rail.</p>
--	--

<p><b>Warning</b></p>	<p><b>SYSTEM LIMITS</b></p> <p>➤ The total length must be for a maximum of 18 modules.</p>
-----------------------	--

Number of modules includes the CPU & Power Module	Rail configuration and terminations	
	Rail configuration	Terminations
2	BRB2	The rail is terminated on the left with the termination "begin" and on the right with the termination "end" (see figure in <i>Tab. 5-8</i> )
4	BRM4	
6	BRB2 + BRM4	
8	2 x BRM4	
10	BRB2 +2 x BRM4	
12	3 x BRM4	
14	BRB2 +3 x BRM4	
16	4 x BRM4	
18	BRB2 +4 x BRM4	

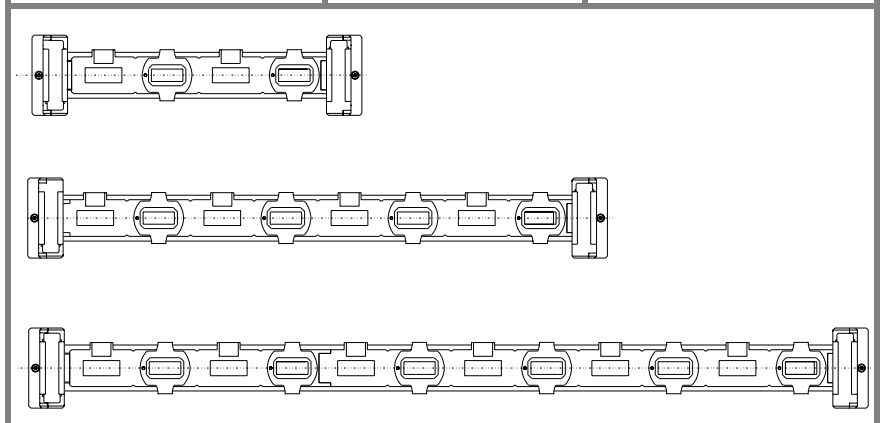



**Tab. 5-8** Length configuration on a rail and terminations used

# OPERATING INSTRUCTIONS FOR THE I.S. 1 SYSTEM

## 5.3.4 2nd configuration alternative for the BusRail – on two rails

### Configuration on two rails

	<p>The permissible BusRail combinations shown in table <i>Tab. 5-9</i> can be built onto two rails (see <i>Tab. 5-11</i>).</p>
 <b>Warning</b>	<p><b>SYSTEM LIMITS</b></p> <ul style="list-style-type: none"> <li>➤ Total length of both rails:              Zone 1: For a max. of 10 modules              Zone 2: For a max. of 18 modules</li> <li>➤ Total length of the BusRail with connection cable must be a maximum of 3 m.</li> </ul>

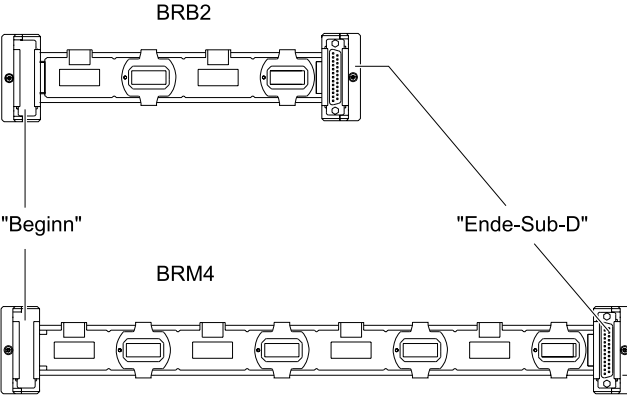
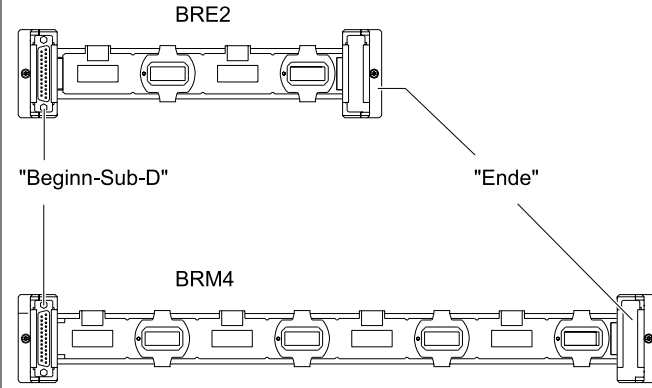
Rail configurations, terminations and permissible connections for two rails	
Rail 1	Rail 2
<p>The first rail is terminated on the left with the termination "begin" and on the right with the termination "end-Sub-D". The first rail in the lengths BRB2 and BRM4 is shown here as an example.</p>	<p>The second rail is terminated on the left with the termination "begin-Sub-D" and on the right with the termination "end". The second rail in the lengths BRE2 and BRM4 is shown here as an example.</p>
	
<p>The length of the connection cable is 110 cm in the standard version.</p>	

**Tab. 5-9** Length extension of the BusRail on two rails and terminations used

### Configuration on two rails (continued)

The variations of the BusRail BRB2, BRM4 and BRE2 can exist in different combinations for the configuration of the first and second rail.

Depending on this combination a certain number of plug-in I/O modules results.

Tab. 5-10 lists the resulting number of plug-in modules at various combinations of the BusRail rails.

Rail 2 \ Rail 1	None	BRE2	BRM4	BRM4 + BRE2	2 x BRM4	2 x BRM4 + BRE2	3 x BRM4	3 x BRM4 + BRE2	4 x BRM4	4 x BRM4 + BRE2
None	--	2	4	6	8	10	12	14	16	18
BRB2	2	4	6	8	10	12	14	16	18	--
BRM4	4	6	8	10	12	14	16	18	--	--
BRB2 + BRM4	6	8	10	12	14	16	18	--	--	--
2 x BRM4	8	10	12	14	16	18	--	--	--	--
BRB2 + 2 x BRM4	10	12	14	16	18	--	--	--	--	--
3 x BRM4	12	14	16	18	--	--	--	--	--	--
BRB2 + 3 x BRM4	14	16	18	--	--	--	--	--	--	--
4 x BRM4	16	18	--	--	--	--	--	--	--	--
BRB2 + 4 x BRM4	18	--	--	--	--	--	--	--	--	--

**Tab. 5-10** Resulting number of plug-in modules

# OPERATING INSTRUCTIONS FOR THE I.S. 1 SYSTEM

## 5.3.5 Options for connecting BusRail rails

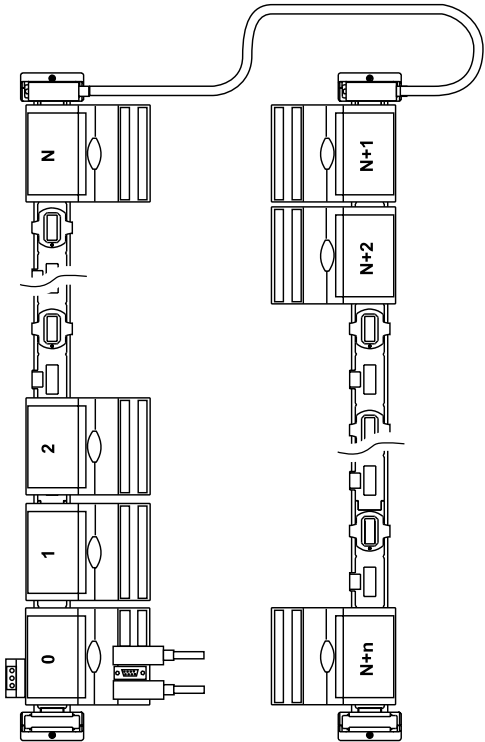
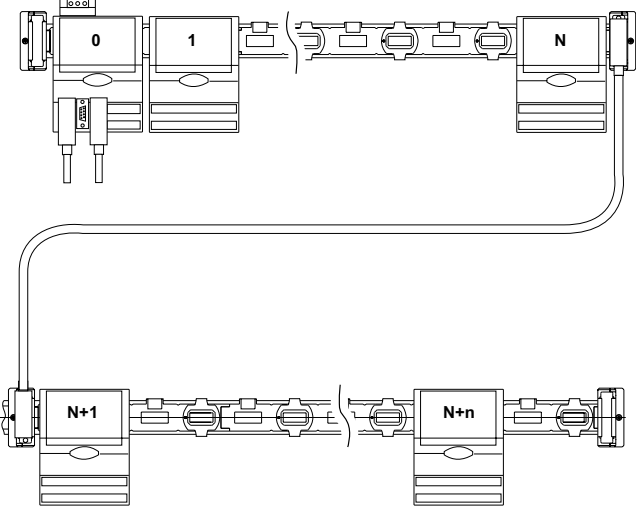
First connection option	Second connection option
	
<p>In the displayed connection, the CPU &amp; Power Module counts the I/O modules on the second rail from top to bottom.</p> <p>The numbers displayed on the I/O modules show an example of the way the CPU &amp; Power Module counts them.</p>	<p>In the displayed connection, the CPU &amp; Power Module counts the I/O modules on the second rail from left to right.</p> <p>The numbers displayed on the I/O modules show an example of the way the CPU &amp; Power Module counts them.</p>

**Tab. 5-11** Options for connecting the BusRail and the resulting addressing of the I/O modules by the CPU & Power Module

## 5.3.6 BusRail engineering – slot allocation

A CPU & Power Module always occupies the first slot on the BusRail.

Tab. 5-12 shows how the individual slots are fitted with modules.

Slot allocation of the BusRail	Module type	Slot name
<b>Without redundant CPU &amp; Power Module</b> 	CPU & Power Module	CPM
	Each I/O module Each I/O module Each I/O module Each I/O module	Mod No 1 Mod No 2 Mod No 3 Mod No ...
<b>With redundant CPU &amp; Power Module</b> 	CPU & Power Module	CPM prim
	CPU & Power Module CPU & Power Module	CPM red
Each I/O module Each I/O module Each I/O module Each I/O module	Mod No 1 Mod No 2 Mod No 3 Mod No ...	

**Tab. 5-12** BusRail engineering (slot allocation)

	<p>For engineering information regarding the properties of the I/O modules and their connections, see Chapter 7.6.</p>
--	--

## 5.4 Engineering information for selection of cable

Type	Summary
ServiceBus	Shielded, twisted wire pair, cross-section 0.5 .. 1.5 mm <sup>2</sup>
Fieldbus	Modbus Shielded, twisted wire pair, cross-section 0.5 .. 1.5 mm <sup>2</sup>
	Profibus Special cable, specifications see "Profibus technical guidelines, configuration guidelines Profibus DP/ FMS" (Profibus user organization), see accessories, Chapter 14.2
Plug for fieldbus	See accessories, Chapter 14.2

**Tab. 5-13** Engineering information for selection of cable

## 5.5 Engineering examples

	<p><b>Field station for use in Zone 1</b></p> <p>Enclosure 8146/5095-3D Reference number: IS1-8146509-1A1</p> <p>Material Glass-fiber reinforced unsaturated polyester resin</p> <p>Dimensions 681.5 x 340.5 x 190 (Length x Width x Depth; specified in [mm])</p> <p>Degree of protection: IP 66</p>
	<p><b>Field station for use in Zone 1</b></p> <p>Enclosure 8146/5095 Combination Reference number: IS1-8146500-1B1</p> <p>Material Glass-fiber reinforced unsaturated polyester resin</p> <p>Dimensions 681.5 x 681.5 x 190 (Length x Width x Depth; specified in [mm])</p> <p>Degree of protection: IP 66</p>
	<p><b>Field station for use in Zone 2</b></p> <p>Enclosure 8146/5095-3D Reference number: IS1-8146509-2A1</p> <p>Material Glass-fiber reinforced unsaturated polyester resin</p> <p>Dimensions 681.5 x 340.5 x 190 (Length x Width x Depth; specified in [mm])</p> <p>Degree of protection: IP 66</p>

**Tab. 5-14** Engineering examples – Field stations in the enclosure made of glass-fiber reinforced unsaturated polyester resin

# OPERATING INSTRUCTIONS FOR THE I.S. 1 SYSTEM

	<p><b>Field station for use in Zone 1</b></p> <p>Enclosure 8125/5585-2D Reference number: IS1-8125558-1A1</p> <p>Material Stainless steel</p> <p>Dimensions 543.5 x 543.5 x 190 (Length x Width x Depth; specified in [mm])</p> <p>Degree of protection: IP 66</p>
	<p><b>Field station for use in Zone 1</b></p> <p>Enclosure 8125/8917-2D Reference number: IS1-8125891-1A1</p> <p>Material Stainless steel</p> <p>Dimensions 730 x 730 x 290 (Length x Width x Depth; specified in [mm])</p> <p>Degree of protection: IP 66</p>
	<p><b>Field station for use in Zone 2</b></p> <p>Enclosure Customer-specific Reference number: IS1-1006030-2A1</p> <p>Material Sheet steel or Stainless steel</p> <p>Dimensions 600 x 1000 x 300 (Length x Width x Depth; specified in [mm])</p> <p>Degree of protection: IP 65 or higher</p>

**Tab. 5-15** Engineering examples – Field stations in the enclosure made of sheet steel / stainless steel

## 5.6 Forms

A three-page offer creation form is available for the engineering of I.S. 1 systems.

### Page 1

Page 1

### I.S. 1 quotation form



---

from: ..... to: S-MSR  
customer: ..... project: ..... date: .....

Ex protection	Installation in	Field circuits	Remarks ...
	<input type="checkbox"/> Safe area	<input type="checkbox"/> non I.S.	
	<input type="checkbox"/> Zone 2	<input type="checkbox"/> I.S.	
	<input type="checkbox"/> Zone 1		

Automation-System	Manufacturer Type	Interface & Protocol	Remarks ...

Enclosure	Material	Protection	Cable entry
	<input type="checkbox"/> Polyester	<input type="checkbox"/> IP 54	<input type="checkbox"/> Cable clands
	<input type="checkbox"/> Steel	<input type="checkbox"/> IP 65	<input type="checkbox"/> Flanch plate
	<input type="checkbox"/> Stainless steel	<input type="checkbox"/> IP ...	<input type="checkbox"/> ...
	Remarks ...		

Power supply			
	<input type="checkbox"/> 24 V DC	<input type="checkbox"/> 110 V AC	<input type="checkbox"/> 230 V AC

Redundancy			
	<input type="checkbox"/> no	<input type="checkbox"/> Fieldbus cable	<input type="checkbox"/> CPU & Power Module

Remarks ...

Fig. 5-4 Offer form – Page 1

# OPERATING INSTRUCTIONS FOR THE I.S. 1 SYSTEM

Page 2

Page 2 

**I.S. 1 quotation form**

---

Total signals	Field station 1		Field station 2		Field station 3	
	Fitted	Spare	Fitted	Spare	Fitted	Spare
(number of signals)						
Analog Input						
Analog Input HART						
Temperature Input R						
Temperature Input mV						
Analog Output						
Analog Output HART						
Digital Input						
Frequency/Counter						
Digital Output						
...						
...						
Fieldbus cable length						
Delivery date						
Remarks ...						

Services to be included in quotation ...

**Fig. 5-5** Offer form – Page 2

Page 3

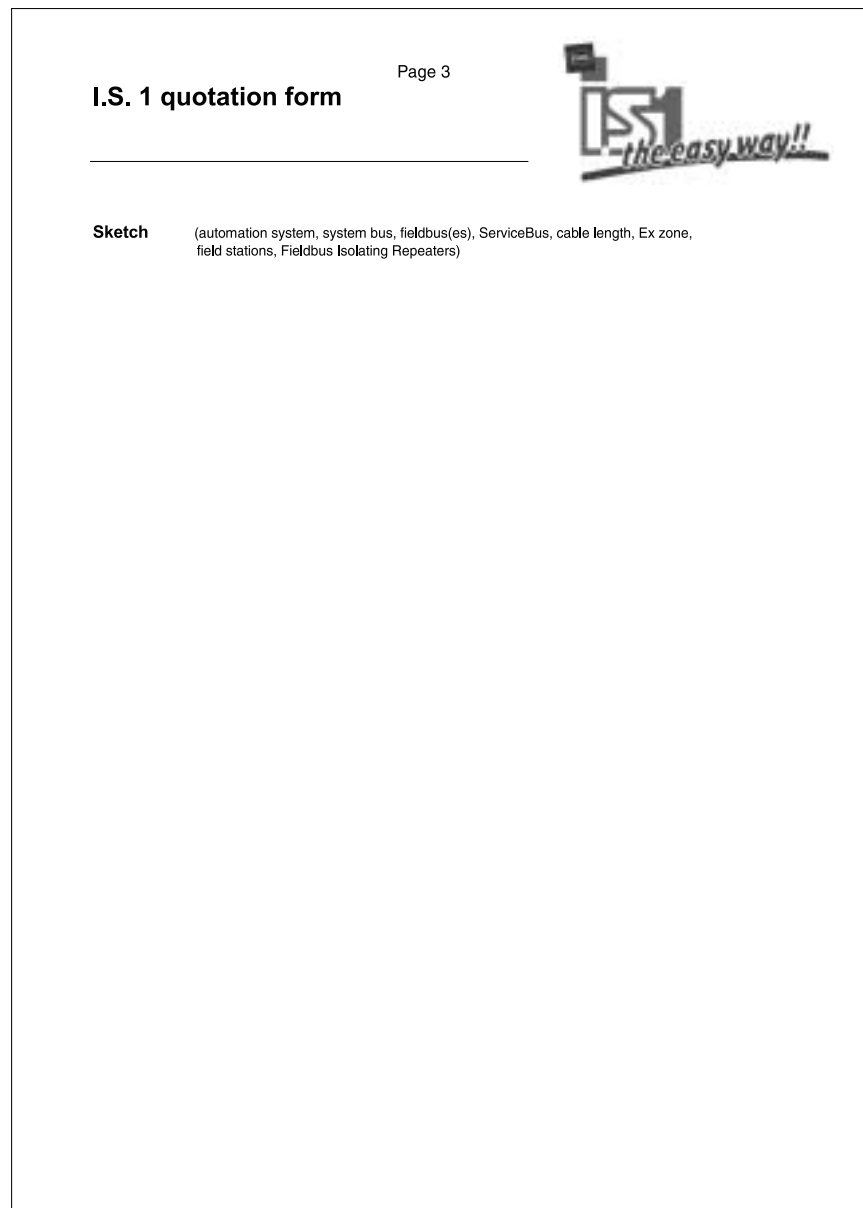

Fig. 5-6 Offer form – Page 3

# **OPERATING INSTRUCTIONS FOR THE I.S. 1 SYSTEM**

---