



7 CONNECTING THE CABLES

7.1 Safety instructions for connecting the cables

	<p>When connecting and laying the cables observe the installation and erection regulations in accordance with EN 60 079-14 as well as state-specific regulations.</p>
---	---

7.1.1 Connecting of I/O module and field device

 Warning	<p>ENDANGERING OF INTRINSIC SAFETY!</p> <p>The connection of an intrinsically safe field device with an intrinsically safe input or output must result in an intrinsically safe circuit!</p> <ul style="list-style-type: none"> ➤ When selecting the field devices to be connected with the I/O modules, check the resulting safe values. ➤ Take into account the inductance and capacitance of the cable.
--	---

Further information regarding proof of intrinsic safety

	<p>See <i>Tab. 5-2</i>: Maximum values of the field devices and field circuits.</p>
---	---

OPERATING INSTRUCTIONS FOR THE I.S. 1 SYSTEM

7.2 Overview of the connections of the I.S. 1 system

CPU & Power Modules and I/O Modules have different connections. *Tab. 7-1* shows the module-specific connections and the working steps for connecting the cables.

Module	Connection	Working step
All modules	All connections	Strip the insulation of the cable
CPU & Power Module	Power supply	Connect the screw terminal to the power supply cable and plug it in
	Fieldbus	Connect the Sub-D socket to the bus cable and plug it in
	Redundant fieldbus	Connect the Sub-D socket to the bus cable and plug it in
	ServiceBus	Connect the Sub-D socket to the bus cable and plug it in
	Connection to the I/O modules	Implemented by plugging into the BusRail
I/O module	Connection to the field devices	Connect the field cable to the plug-in terminal and plug it in
	Connection to the CPU & Power Module and power supply	Implemented by plugging into the BusRail

Tab. 7-1 Overview of the working steps for connecting the cables to the modules

7.3 Preparation for connecting

Hundreds of different cables can run together in an I.S. 1 system via the various field stations. Connecting such a high number of cables requires special preparation of the connecting process.

7.3.1 Assigning cables

The following steps are required for the rough assignment of the cable bundles to the specific modules and for preparing the connection process:

- Keep the interface allocation plan at hand.
- Assign the cable bundles to the modules in accordance with the interface allocation plan.
- Strip the insulation off the cables and conductors.
- Place end sleeves on the bared conductor ends and crimp them.

7.3.2 Required state of the system

The system has to be in the following state after connection of the cables to the modules has been prepared:

- Cables bared and end sleeves fitted
- Assign the cable bundles to the I/O modules in accordance with the interface allocation plan

7.4 Connection allocation of the CPU & Power Module for Zone 1, Type 9440/12

7.4.1 Connection diagram

The CPU & Power Module for Zone 1 has five different connection possibilities. The five connection possibilities are designated with X1 to X5 in Fig. 7-1.

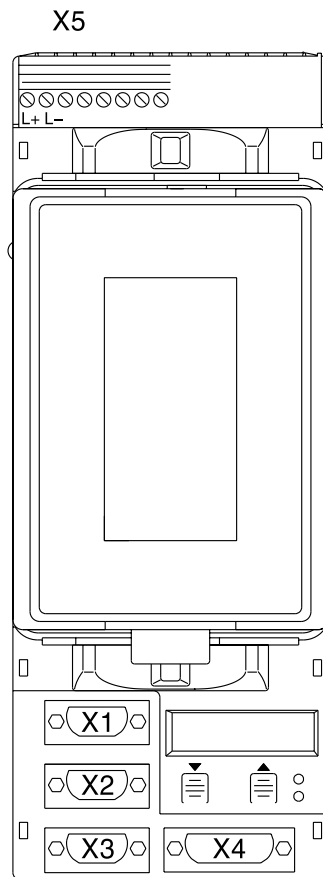

Fig. 7-1 Connections at the base of the CPU & Power Module for Zone 1

- X1** Fieldbus
- X2** Redundant fieldbus
- X3** ServiceBus
- X4** Data plug
- X5** Power supply

7.4.2 Power supply (X5)

The CPU & Power Module for Zone 1 is supplied with the required power supply by a cable.

The cable is connected to the EEx e terminals of the base.

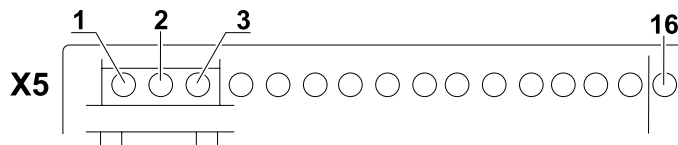

Fig. 7-2 Terminal allocation of the EEx e terminals for power supply (view from above)

- 1 +
- 2 -
- 3 to 16 not occupied

The following table shows the terminal allocation for the power supply:

Description	Function	Connector number	Terminal 16 pin designation
	24 V DC (+)	X5	+
	0 V	X5	-
	Not connected	X5	Terminals 3..16

Tab. 7-2 Terminal allocation for the power supply

OPERATING INSTRUCTIONS FOR THE I.S. 1 SYSTEM

7.4.3 Fieldbus (X1) / Fieldbus redundant (X2)

The following table shows the pin allocation of the primary (X1) and of the redundant fieldbus plug (X2):

Description	Function	Connector number	Sub-D 9 plug Pin No.
Data B (+)	RxD/TxD (+)	X1/X2	3
Data A (-)	RxD/TxD (-)	X1/X2	8
--	Not connected	X1/X2	1, 2, 4, 5, 6, 7, 9

Tab. 7-3 Pin allocation of the fieldbus pins X1 and X2

7.4.4 ServiceBus (X3)

The following table shows the pin allocation for the ServiceBus plug:

Description	Function	Connector number	Sub-D 9 plug Pin No.
Data B (+)	RxD/TxD (+)	X3	3
Data A (-)	RxD/TxD (-)	X3	8
--	Not connected	X3	1, 2, 4, 5, 6, 7, 9

Tab. 7-4 Pin allocation of the ServiceBus plug X3

7.5 Connection allocation of the CPU & Power Module for Zone 2, Type 9440/15-01-11

7.5.1 Connection diagram

The CPU & Power Module for Zone 2 has five different connection possibilities. The five connection possibilities are designated with X1 to X5 in Fig. 7-3.

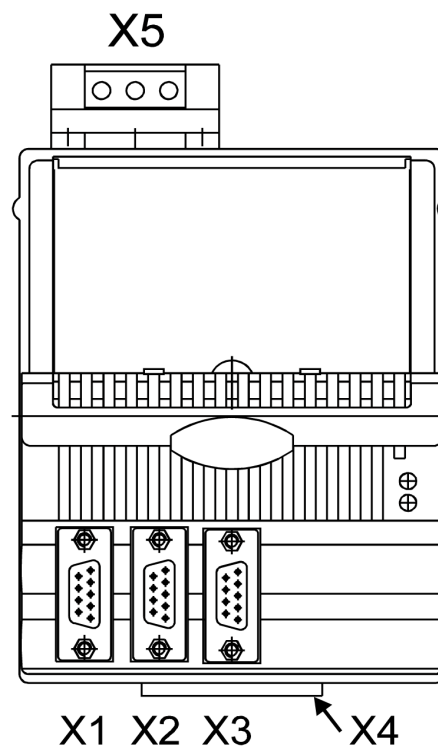

Fig. 7-3 Connection diagram of the CPU & Power Module for Zone 2

- X1** Fieldbus
- X2** Redundant fieldbus
- X3** ServiceBus
- X4** Data plug
- X5** Power supply

OPERATING INSTRUCTIONS FOR THE I.S. 1 SYSTEM

7.5.2 Power supply (X5)

The CPU & Power Module is supplied with the required power supply by a cable.

A 3-pin screw terminal is used to connect the cable to the module (see Fig. 7-4).

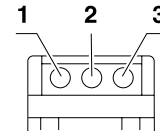

Fig. 7-4 Pin allocation of the 3-pin plug-in terminal for the power supply (view from above)

- 1 +
- 2 -
- 3 not occupied

The following table shows the terminal allocation plan for the screw terminal:

Description	Function	Connector number	Terminal 3 pin designation
Screw terminal	24 V DC (+)	X5	+
	0 V	X5	-
	No conductor connection	X5	--

Tab. 7-5 Terminal allocation plan for the power supply X5

7.5.3 Fieldbus (X1)/Fieldbus redundant (X2)

Sub-D plug

Fig. 7-5 shows the individual pins and the Sub-D plugs used.

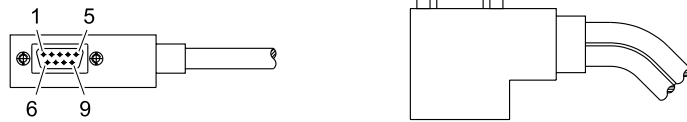

Fig. 7-5 Pin allocation of the Sub-D plug

- 1 Pin 1
- 5 Pin 5
- 6 Pin 6
- 9 Pin 9

The following table shows the pin allocation of the primary (X1) and of the redundant fieldbus plug (X2):

Description	Function	Connector number	Sub-D 9 plug Pin No.
Data B (+)	RxD/TxD (+)	X1/X2	3
Ground for interface (from device)	GND	X1/X2	5
Supply voltage (from device)	5 V (+)	X1/X2	6
Data A (-)	RxD/TxD (-)	X1/X2	8
--	Not connected	X1/X2	1, 2, 4, 7, 9

Tab. 7-6 Pin allocation of the fieldbus pins X1 and X2

OPERATING INSTRUCTIONS FOR THE I.S. 1 SYSTEM

7.5.4 ServiceBus (X3)

The following table shows the pin allocation for the ServiceBus plug:

Description	Function	Connector number	Sub-D 9 plug Pin No.
Data B (+)	RxD/TxD (+)	X3	3
Ground for interface (from device)	GND	X3	5
Supply voltage (from device)	5 V (+)	X3	6
Data A (-)	RxD/TxD (-)	X3	8
--	Not connected	X3	1, 2, 4, 7, 9

Tab. 7-7 Pin allocation of the ServiceBus plug X3

7.6 Connection allocation of the I/O module

	<p>An I/O module may be connected to the field device by different means. The terminal allocation may therefore differ.</p>
--	---

7.6.1 Connection diagram of the I/O modules (Type 9470, 9471 and 9480)

The I/O modules have two terminal strips for field devices.
 The designation X1 is used in the diagram below for the two terminal strips for field devices (plug-in terminals).
 The two plug-in terminals X1 have 16 terminals each for connecting the field cables.

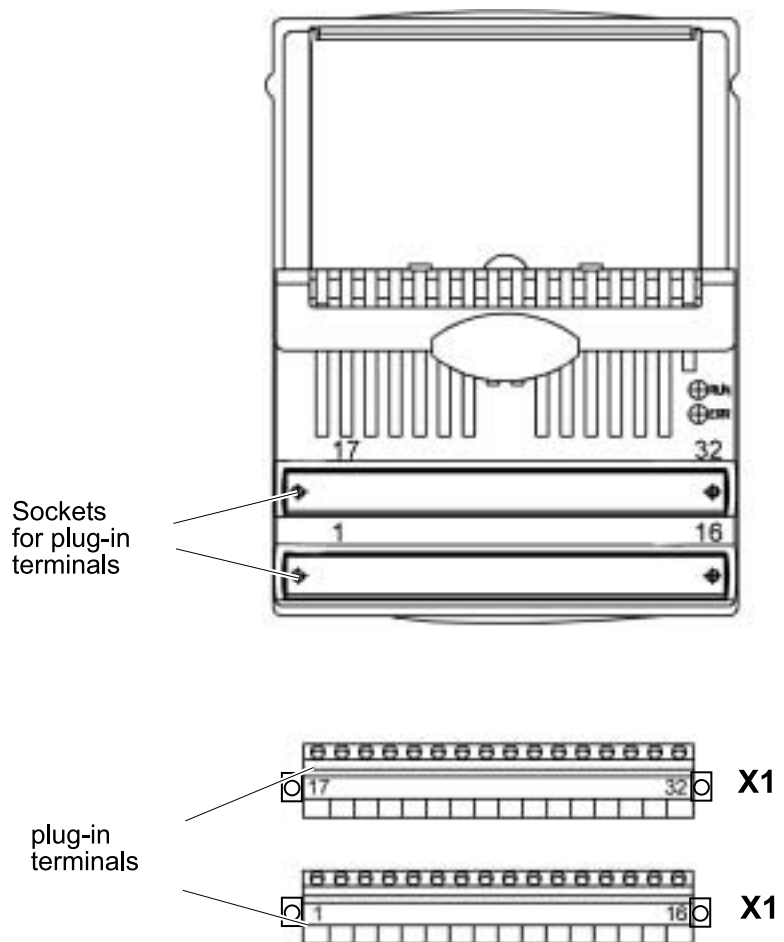

Fig. 7-6 Connection diagram of the I/O modules Type 9470 and 9480

OPERATING INSTRUCTIONS FOR THE I.S. 1 SYSTEM

7.6.2 Connection diagram of the I/O modules (Type 9460, 9461, 9465, 9475, 9477 and 9481)

The I/O modules have one terminal strip for field devices.
The designation X1 is used in the diagram below for the terminal strip for field devices (plug-in terminal).
The plug-in terminal X1 have 16 terminals for connecting the field cables.

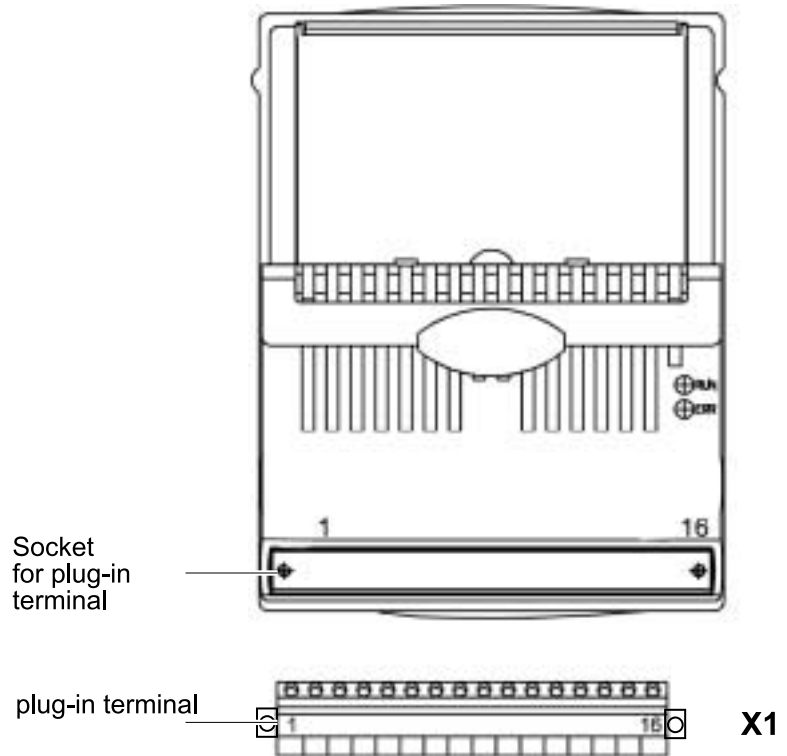

Fig. 7-7 Connection diagram of the I/O modules (Type 9460, 9461, 9465, 9466, 9475 and 9481)

7.6.3 Analog Input Module, Type 9460

Some of the connectable field device types are drawn in in *Fig. 7-8*.

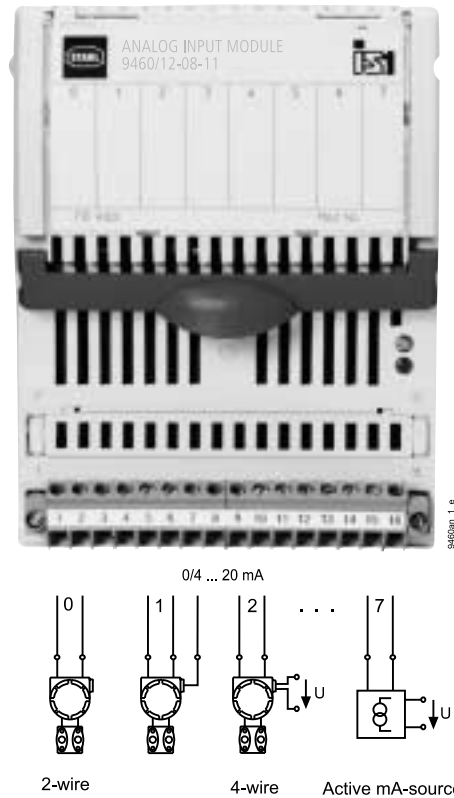

Fig. 7-8 Analog Input Module Type 9460 (connectable field device types)

2-wire transmitter for AIM 9460

The following table shows the connection allocation of the Analog Input Module for 2-wire transmitter:

Channel No.	Function 2-wire transmitter	Plug X1 Terminal No.
0 0	Input (+) Input (-)	1 2
1 1	Input (+) Input (-)	3 4
...
7 7	Input (+) Input (-)	15 16

Tab. 7-8 Connection allocation of the Analog Input Module for 2-wire-transmitter

OPERATING INSTRUCTIONS FOR THE I.S. 1 SYSTEM

3- and 4-wire transmitters for AIM 9460

The following table shows the connection allocation of the Analog Input Module for 3 and 4-wire transmitters:

Channel No.	Function 3-wire transmitter	Function 4-wire transmitter	Plug X1 Terminal No.
0 0 1 (not occupied) 1 (not occupied)	Power (+) Input (-) No conductor connection Input (-)	No conductor connection Input (+) No conductor connection Input (-)	1 2 3 4
2 2 3 (not occupied) 3 (not occupied)	Power (+) Input (-) No conductor connection Input (-)	No conductor connection Input (+) No conductor connection Input (-)	5 6 7 8
...
6 6 7 (not occupied) 7 (not occupied)	Power (+) Input (-) No conductor connection Input (-)	No conductor connection Input (+) No conductor connection Input (-)	13 14 15 16

Tab. 7-9 Connection allocation of the Analog Input Module for 3 and 4-wire transmitters

7.6.4 Analog Input Module HART, Type 9461/1.-08-1.

Some of the connectable field device types are drawn in in Fig. 7-9.

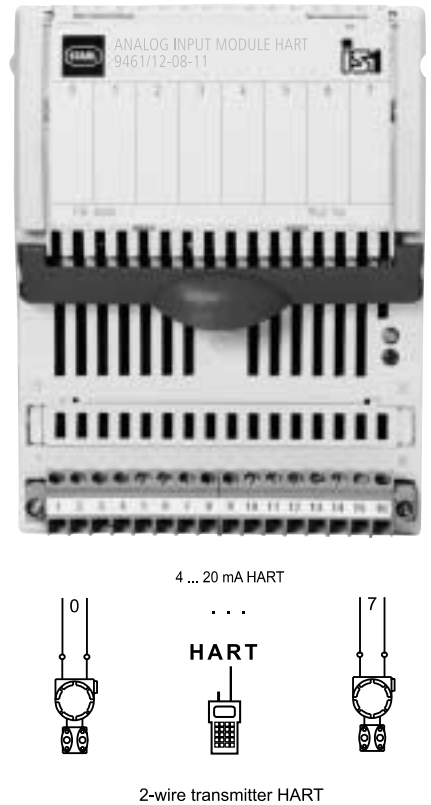

Fig. 7-9 HART Analog Input Module, Type 9461/...-1. (connectable field device types)

2-wire transmitter for AIM HART 9461/1.-08-1.

The following table shows the connection allocation of the Analog Input Module HART for 2-wire transmitter:

Channel No.	Function 2-wire transmitter	Plug X1 Terminal No.
0 0	Input (+) Input (-)	1 2
1 1	Input (+) Input (-)	3 4
...
7 7	Input (+) Input (-)	15 16

Tab. 7-10 Connection allocation of the Analog Input Module HART for 2-wire-transmitter

OPERATING INSTRUCTIONS FOR THE I.S. 1 SYSTEM

7.6.5 Analog Input Module HART, Type 9461/1.-08-2.

Some of the connectable field device types are drawn in in *Fig. 7-10*.

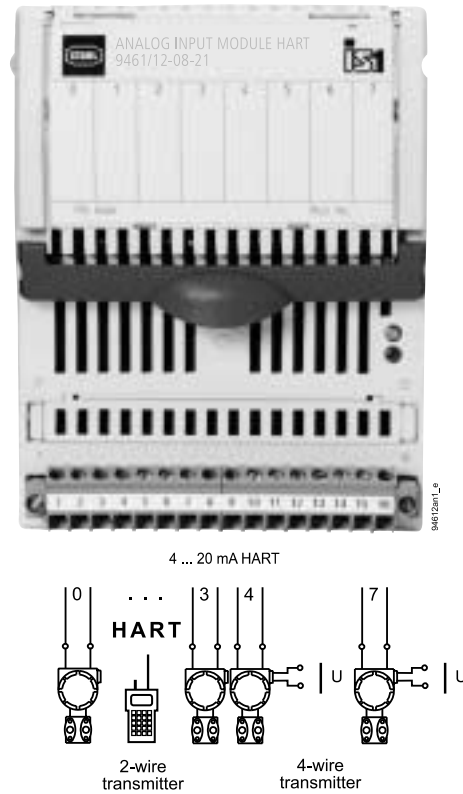

Fig. 7-10 Analog Input Module HART, Type 9461/1.-08-2.
(connectable field device types)

2- and 4-wire transmitters for AIM HART 9461/1.-08-2.

The following table shows the connection allocation of the Analog Input Module HART for 2 and 4-wire transmitters:

Channel No.	Function 2-wire transmitter	Function 4-wire transmitter	Plug X1 Terminal No.
0 0	Input (+) Input (-)	-- --	1 2
1 1	Input (+) Input (-)	-- --	3 4
2 2	Input (+) Input (-)	-- --	5 6
3 3	Input (+) Input (-)	-- --	7 8
4 4	-- --	Input (+) Input (-)	9 10
5 5	-- --	Input (+) Input (-)	11 12
6 6	-- --	Input (+) Input (-)	13 14
7 7	-- --	Input (+) Input (-)	15 16

Tab. 7-11 Connection allocation of the Analog Input Module HART for 2 and 4-wire transmitters

OPERATING INSTRUCTIONS FOR THE I.S. 1 SYSTEM

7.6.6 Temperature Input Module R, Type 9480

Some of the connectable field device types are drawn in in Fig. 7-11.

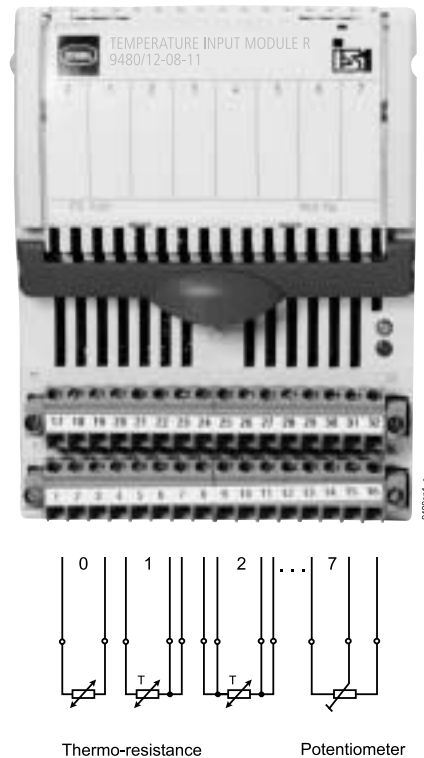

Fig. 7-11 Temperature Input Module R Type 9480 (connectable field device types)

2-wire circuit for TIMR 9480

The following table shows the connection allocation of the Temperature Input Module R for Pt 100 (2-wire circuit):

Channel	Function Pt 100 (2-wire circuit)	Plug X1 Terminal No.
0	Sensor current (+), voltage (+)	1
0	No conductor connection	2
0	No conductor connection	3
0	Sensor current (-), voltage (-)	4
1	Sensor current (+), voltage (+)	5
1	No conductor connection	6
1	No conductor connection	7
1	Sensor current (-), voltage (-)	8
...
7	Sensor current (+), voltage (+)	29
7	No conductor connection	30
7	No conductor connection	31
7	Sensor current (-), voltage (-)	32

Tab. 7-12 Connection allocation of the Temperature Input Module R for Pt 100 (2-wire circuit)

3-wire circuit for TIMR 9480

The following table shows the connection allocation of the Temperature Input Module R for Pt 100 (3-wire circuit):

Channel	Function Pt 100 (3-wire circuit)	Plug X1 Terminal No.
0	Sensor current (+), voltage (+)	1
0	No conductor connection	2
0	Voltage (-)	3
0	Sensor current (-)	4
1	Sensor current (+), voltage (+)	5
1	No conductor connection	6
1	Voltage (-)	7
1	Sensor current (-)	8
...
7	Sensor current (+), voltage (+)	29
7	No conductor connection	30
7	Voltage (-)	31
7	Sensor current (-)	32

Tab. 7-13 Connection allocation of the Temperature Input Module R for Pt 100 (3-wire circuit)

4-wire circuit for TIMR 9480

The following table shows the connection allocation of the Temperature Input Module R for Pt 100 (4-wire circuit):

Channel	Function Pt 100 (4-wire circuit)	Plug X1 Terminal No.
0	Sensor current (+)	1
0	Voltage (+)	2
0	Voltage (-)	3
0	Sensor current (-)	4
1	Sensor current (+)	5
1	Voltage (+)	6
1	Voltage (-)	7
1	Sensor current (-)	8
...
7	Sensor current (+)	29
7	Voltage (+)	30
7	Voltage (-)	31
7	Sensor current (-)	32

Tab. 7-14 Connection allocation of the Temperature Input Module R for Pt 100 (4-wire circuit):

OPERATING INSTRUCTIONS FOR THE I.S. 1 SYSTEM

Potentiometer in 3-wire circuit for TIMR 9480

The following table shows the connection allocation of the Temperature Input Module R for potentiometers with a 3-wire circuit:

Channel	Function Potentiometer with a 3-wire circuit	Plug X1 Terminal No.
0	Resistor end (sensor current (+))	1
0	No conductor connection	2
0	Wiper (voltage (-))	3
0	Resistor beginning (sensor current (-))	4
1	Resistor end (sensor current (+))	5
1	No conductor connection	6
1	Wiper (voltage (-))	7
1	Resistor beginning (sensor current (-))	8
...
7	Resistor end (sensor current (+))	29
7	No conductor connection	30
7	Wiper (voltage (-))	31
7	Resistor beginning (sensor current (-))	32

Tab. 7-15 Connection allocation of the Temperature Input Module R for potentiometer with a 3-wire circuit:

7.6.7 Temperature Input Module mV, Type 9481

Some of the connectable field device types are drawn in in *Fig. 7-12*.

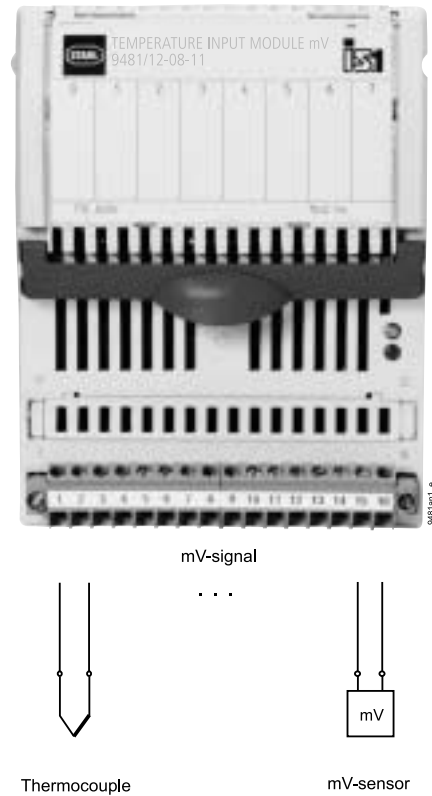

Fig. 7-12 Temperature Input Module mV Type 9481 (connectable field device types)

2-wire circuit for TIMmV 9481

The following table shows the connection allocation of the Temperature Input Module mV:

Channel	Function mV input	Plug X1 Terminal No.
0 0	Input (+) Input (-)	1 2
1 1	Input (+) Input (-)	3 4
...
7 7	Input (+) Input (-)	15 16
0 .. 7	Reference junction	Internal

Tab. 7-16 Connection allocation of the Temperature Input Module mV

OPERATING INSTRUCTIONS FOR THE I.S. 1 SYSTEM

7.6.8 Analog Output Module, Type 9465

Some of the connectable field device types are drawn in in *Fig. 7-13*.

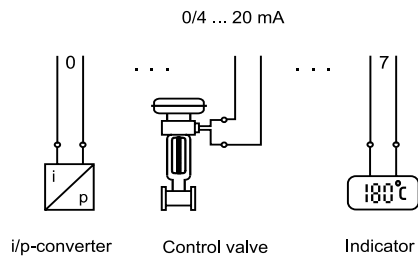

Fig. 7-13 Analog Output Module Type 9465 (connectable field device types)

Connection allocation per channel at the AOM 9465

The following table shows the connection allocation of the Analog Output Module:

Channel No.	Function Output	Plug X1 Terminal No.
0	Output (+)	1
0	Output (-)	2
1	Output (+)	3
1	Output (-)	4
...
7	Output (+)	15
7	Output (-)	16

Tab. 7-17 Connection allocation of the Analog Output Module

7.6.9 HART Analog Output Module, Type 9466

Some of the connectable field device types are drawn in in *Fig. 7-14*.

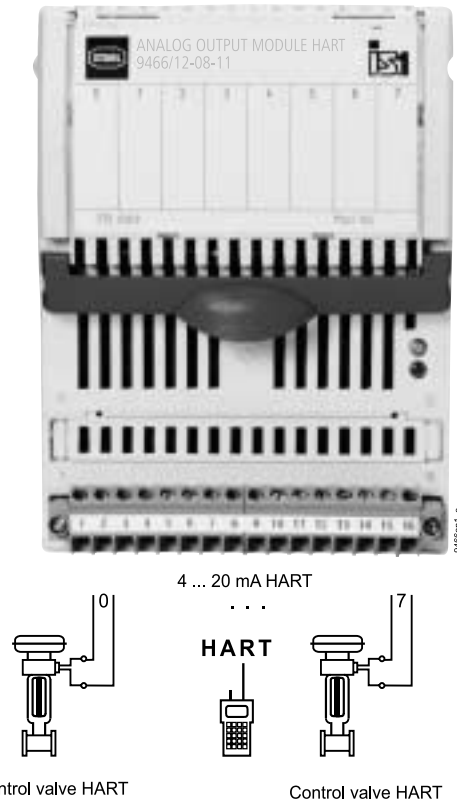

Fig. 7-14 HART Analog Output Module Type 9466 (connectable field device types)

Connection allocation per channel at the AOM HART 9466

The following table shows the connection allocation of the HART Analog Output Module:

Channel No.	Function Output	Plug X1 Terminal No.
0 0	Output (+) Output (-)	1 2
1 1	Output (+) Output (-)	3 4
...
7 7	Output (+) Output (-)	15 16

Tab. 7-18 Connection allocation of the HART Analog Output Module

7.6.10 NAMUR Digital Input Module, Type 9470

Some of the connectable field device types are drawn in in *Fig. 7-15*.

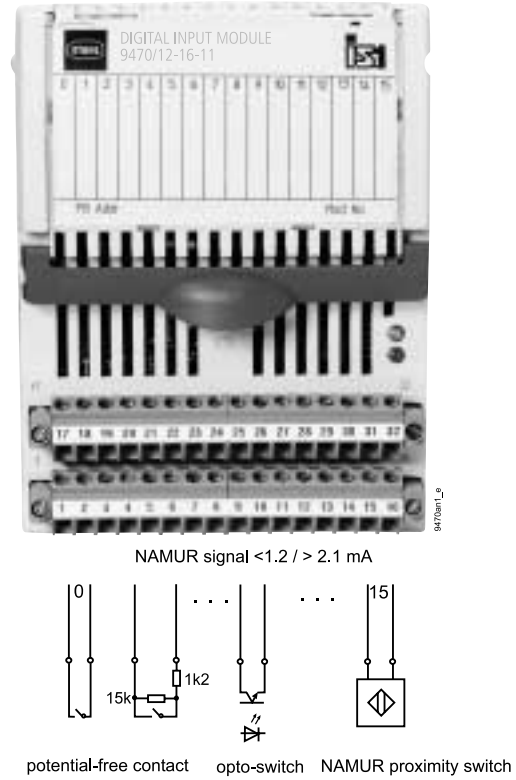

Fig. 7-15 NAMUR Digital Input Module mV Type 9470 (connectable field device types)

Connection allocation per channel at the DIM NAMUR 9470

The following table shows the connection allocation of the Digital Input Module:

Channel No.	Function Input	Plug X1 Terminal No.
0 0	Input (+) Input (-)	1 2
1 1	Input (+) Input (-)	3 4
...
15 15	Input (+) Input (-)	31 32

Tab. 7-19 Connection allocation of the NAMUR Digital Input Module

7.6.11 Digital Input Module 24 V, Type 9471

Some of the connectable field device types are drawn in in *Fig. 7-16*.

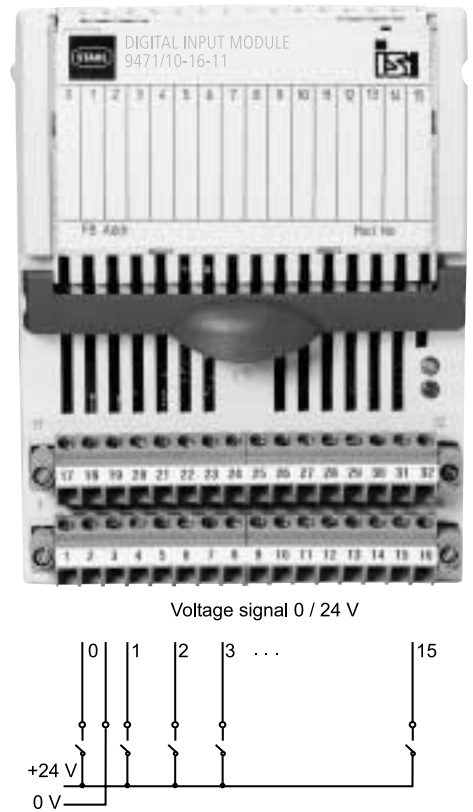

Fig. 7-16 Digital Input Module 24 V Type 9471 (connectable field device types)

Connection allocation per channel at the DIM 24 V 9471

The following table shows the connection allocation of the Digital Input Module:

Channel No.	Function Input	Plug X1 Terminal No.
0	Input (+)	1
0	Input (-)	2
1	Input (+)	3
1	Input (-)	4
...
15	Input (+)	31
15	Input (-)	32

Tab. 7-20 Connection allocation of the Digital Input Module

OPERATING INSTRUCTIONS FOR THE I.S. 1 SYSTEM

7.6.12 Digital Output Module, Type 9475

Some of the connectable field device types are drawn in in Fig. 7-17.

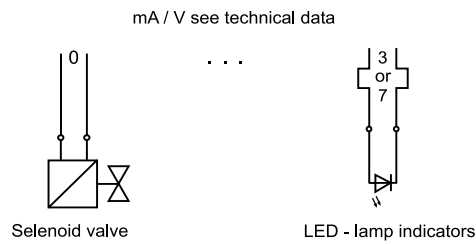

Fig. 7-17 Digital Output Module Type 9475 (connectable field device types)

**4 channels for DOM 9475/..-04-
..**

The following table shows the connection allocation of the Digital Output Module with 4 channels:

Channel No.	Function Output	Plug X1 Terminal No.
0 0	Output (+) Output (-)	1 2
1 1	Output (+) Output (-)	5 6
...
3 3	Output (+) Output (-)	13 14

Tab. 7-21 Connection allocation of the Digital Output Module with 4 channels

8 channels for DOM 9475/..-08- ..

The following table shows the connection allocation of the Digital Output Module with 8 channels:

Channel No.	Function Output	Plug X1 Terminal No.
0	Output (+)	1
0	Output (-)	2
1	Output (+)	3
1	Output (-)	4
...
7	Output (+)	15
7	Output (-)	16

Tab. 7-22 Connection allocation of the Digital Output Module with 8 channels

OPERATING INSTRUCTIONS FOR THE I.S. 1 SYSTEM

7.6.13 Digital Output Module Relay, Type 9477

Some of the connectable field device types are drawn in in *Fig. 7-18*.



Potential free contact ("1" = closed)



Fig. 7-18 Digital Output Module Relay Type 9477 (connectable field device types)

Connection allocation per channel at the DOMR 9477

The following table shows the connection allocation of the Digital Output Module Relay:

Channel No.	Function	Plug X1 Terminal No.
0	NO contact A	1
0	NO contact B	2
1	NO contact A	3
1	NO contact B	4
...
7	NO contact A	15
7	NO contact B	16

Tab. 7-23 Connection allocation of the Digital Output Module Relay

7.7 Connecting the I/O modules

Field cables suitable for intrinsically safe circuits are to be used to connect the I/O modules to the field devices (sensors and actuators).

 <p>Warning</p>	<p>ENDANGERING OF INTRINSIC SAFETY!</p> <p>The intrinsic safety is endangered if an I/O module is interchanged or the terminals connected incorrectly to the field devices.</p> <ul style="list-style-type: none"> ➤ Only connect Ex I circuits to I/O modules with intrinsically safe inputs or outputs. ➤ Check the module and field device connection.
---	--

7.7.1 Connection to the field devices

The specific connections have to be localized in order to connect the I/O modules to the field devices. Proceed as follows to do so:

- Identify the field cables in accordance with the project-specific wiring diagram.
- Identify the corresponding I/O module type and its terminal allocation (see Chapter 7.6).

7.8 Connection allocation of the terminations

7.8.1 Termination (connection diagram for Type 9494/A2-..)

Fig. 7-19 shows an example of an "end" termination with Sub-D socket. The terminations with Sub-D socket contact the BusRail at the side and has a 25-pin Sub-D socket.

The connection to a further BusRail rail is carried out by means of a special connection cable (see Chapter 4.5.3).

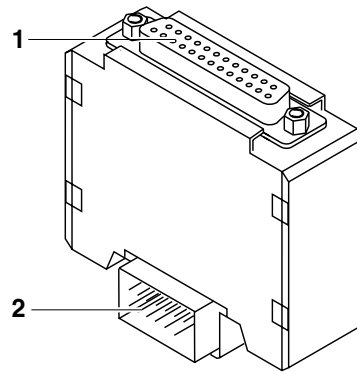

Fig. 7-19 Connection allocation of termination with Sub-D-25 plug

- 1 Connecting plug to the next termination
- 2 Electrical contact to the BusRail

Sub-D-25 socket (pin allocation) at the BusRail 9494

The following table shows the pin allocation at the termination of the BusRail at the Sub-D-25 socket:

Function	Sub-D 25 socket Pin No.
With function	1, 2, 3, 4
Ground	5
Internal bus primary	6
Internal bus redundant	7
Bank 1	8
Bank 2	9
Without function	10
+24 V	11, 12, 13
Without function	14, 15
Ground	16, 17, 18, 19
Bank 3	20
Bank 4	21
Without function	22, 23
+24 V	24, 25

Tab. 7-24 Pin allocation at the termination with the Sub-D socket of the BusRail

OPERATING INSTRUCTIONS FOR THE I.S. 1 SYSTEM
