



05832E00

CPU & Power Module and Sockets for Installation in Zone 1 / Div. 1 Series 9440/22; Series 9490

- Fieldbus interface / gateway and power supply in a single module
- Intrinsically safe fieldbus and ServiceBus acc. RS 485-IS (PNO-Standard)
- Integrated Ex i power supply for up to 8 I/O modules
- Profibus DP V0 and V1 HART, up to 1.5 MBit/s, with optional redundancy
- Modbus RTU, up to 38.4 kBit/s
- Additional ServiceBus interface for commissioning, fault diagnostics and Asset Management System
- LCD indicator for local display of diagnostic data, input and output values
- Module can be replaced in Zone 1 / Div. 1 in operation (hot swap)



The CPU & Power Module (CPM) contains the power supply unit for intrinsically safe supply of power to the I/O modules and field circuits. The power supply unit is fitted with undervoltage monitoring.

The CPM has the function of a gateway between the internal bus in an IS1 field station and the Ex i fieldbus that connects the field station to the automation system.

The interface of the CPU & Power Module with the internal data bus and the I/O modules is designed with redundancy.

The CPM can be separated from the socket during operation (hot swap) even in Zone 1 / Division 1 installations. The auxiliary power connection is made via Ex e terminals or a pre-wired sealed cable in rigid conduit.

Zone	0	1	2	20	21	22
Class	I			II / III		
Zone	0	1	2	20	21	22
Ex interface		X	X		X	X
Installation in		X	X		X ^{*)}	X ^{*)}

Class	I		II / III	
Division	1	2	1	2
Ex interface	X	X	X	X
Installation in	X	X	X ^{*)}	X ^{*)}

^{*)} suitable enclosure necessary

Selection Table					
Version	Installation in	Fieldbus	Power supply	Order number	Weight kg / lbs
CPU & Power Modules (without sockets)	Zone 1 / Division 1	Profibus DP V0	24 V DC	9440/22-01-11	2.963 / 6.532
		Profibus DP V1 HART	24 V DC	9440/22-01-11-C1243	2.963 / 6.532
		Modbus RTU	24 V DC	9440/22-01-11-C1202	2.963 / 6.532
		Profibus DP V0	90 V ... 253 V AC	9440/22-01-21	2.963 / 6.532
		Profibus DP V1 HART	90 V ... 253 V AC	9440/22-01-21-C1243	2.963 / 6.532
		Modbus RTU	90 V ... 253 V AC	9440/22-01-21-C1202	2.963 / 6.532
Sockets for CPU & power module	Zone 1; connection by means of Ex e terminals		24 V DC, 90 V ... 253 V AC	9490/11-12	0.482 / 1.063
	Division 1; connection via conduit*)		24 V DC, 90 V ... 253 V AC	9490/12-12	0.900 / 1.984
	Zone 1; connection via pig tail		24 V DC, 90 V ... 253 V AC	9490/13-12	0.900 / 1.984
*) For orders inside the USA, please use 9490/12-12-dc for DC, pre-wired 9490/12-12-ac for AC, pre-wired plus conduit hub 9491/00-13-70 as accessory					





Explosion Protection	
Certificates	
IECEX	KEM 08.0038X
Europe (ATEX)	KEMA 02 ATEX 1333 X
USA (NEC)	3007532 (FM)
Russia (GOST-R)	04.B00806 (CTB)
Other countries	Canada (CSA), Brazil (INMETRO), Belarus (Promatomnadzor)
Marking	
IECEX	9440/22-01-.1: Ex d [ia/ib] IIC T4 9490/11-12: Ex d e [ia/ib] IIC T4 9490/13-12: Ex d mb [ia/ib] IIC T4
Europe (ATEX)	9440/22-01-.1: Ⓜ II 2 G EEx de [ia/ib] IIC T4 9490/11-12: Ⓜ II 2 G EEx de [ia/ib] IIC T4 9490/13-12: Ⓜ II 2 G EEx dm [ia/ib] IIC T4
USA (NEC)	9440/22-01-.1 & 9490/12-12: XP/II/1/ABCD/T6 Ta = 65 °C, XP/II/1/IIC/T4 Ta = 65 °C, AIS/I,II,III/1/ABCDEFG, AIS/II/1/[AEx ia, ib] IIC
Russia (GOST-R)	9440/22-01-.1 & 9490/11-12: 2Exde[ia/ib]IIC T4 9440/22-01-.1 & 9490/13-12: 2Exdm[ia/ib]IIC T4
Other certificates	Marine (DNV, ABS)
Safety data	
Max. output voltage	$U_{out} / V_o = 26.2 \text{ V}$ to supply the I/O modules
Connection to intrinsically safe RS 485-IS fieldbus	PTB 04 ATEX 2089; Ⓜ II 2 G SYST EEx ib IIC T4
Maximum values for fieldbus and ServiceBus	
Max. voltage	$U_o / V_{oc} = 3.7 \text{ V}$ $U_i / V_{max} = +/- 4.2 \text{ V}$
Max. current	$I_o / I_{sc} = 134 \text{ mA}$
Max. power	$P_o = 124 \text{ mW}$
Max. capacitance for IIC	$C_o / C_a = 1000 \mu\text{F}$
Max. inductance for IIC	$L_o / L_a = 1.9 \text{ mH}$
Further information	see respective certificate



Technical Data		
Types	9440/22-01-11 (24 V DC)	9440/22-01-21 (90 ... 253 V AC)
Interfaces for fieldbus, redundant fieldbus and ServiceBus		
Interface	RS 485-IS acc. to Profibus specification	RS 485-IS acc. to Profibus specification
Maximum cable length	1200 m / 3937 ft with ≤ 93.75 kBit/s and copper cable 200 m / 656 ft with 1.5 MBit/s and copper cable approx. 2000 m / 6562 ft with 1.5 MBit/s and fibre optic cable For further information see operating instructions.	1200 m / 3937 ft with ≤ 93.75 kBit/s and copper cable 200 m / 656 ft with 1.5 MBit/s and copper cable approx. 2000 m / 6562 ft with 1.5 MBit/s and fibre optic cable For further information see operating instructions.
Maximum transfer rate		
Fieldbus	1.5 MBit/s	1.5 MBit/s
ServiceBus	9.6 kBit/s	9.6 kBit/s
Line termination	powered resistor (the termination resistor is installed in the Sub-D plug, see accessories)	powered resistor (the termination resistor is installed in the Sub-D plug, see accessories)
Address range	0 ... 127	0 ... 127
Redundancy	Full redundancy and line redundancy	Full redundancy and line redundancy
Profibus		
Versions	DP V0, DP V1, DP V1 HART	DP V0, DP V1, DP V1 HART
Transfer rate	9.6 kBit / s ... 1.5 MBit / s	9.6 kBit / s ... 1.5 MBit / s
Data transmission (cyclic) net at 1.5 MBit/s	approx. 40 16-bit words / ms	approx. 40 16-bit words / ms
Modbus RTU		
Transfer rate	9.6 kBit/s 19.2 kBit/s 38.4 kBit/s	9.6 kBit/s 19.2 kBit/s 38.4 kBit/s
Data transmission	approx. 1000 16-bit-registers / s (at 38.4 kBit / s)	approx. 1000 16-bit-registers / s (at 38.4 kBit / s)
Functions	Read, Write; see Modbus RTU coupling instructions	Read, Write; see Modbus RTU coupling instructions
ServiceBus		
Functions	<ul style="list-style-type: none"> • Load or read back configuration data and parameters in the IS1 field stations • Read inputs • Read and write outputs • Transfer diagnosis data • Transfer HART commands to/from HART field devices. 	<ul style="list-style-type: none"> • Load or read back configuration data and parameters in the IS1 field stations • Read inputs • Read and write outputs • Transfer diagnosis data • Transfer HART commands to/from HART field devices.
Connectable software packages	<ul style="list-style-type: none"> • I.S. Wizard • R. STAHL DTM • Cornerstone by ASTEC • AMS by Emerson Process Management • PDM by Siemens • PRM and Fieldmate by Yokogawa • FieldCare by Endress + Hauser • FDM by Honeywell • etc. 	<ul style="list-style-type: none"> • I.S. Wizard • R. STAHL DTM • Cornerstone by ASTEC • AMS by Emerson Process Management • PDM by Siemens • PRM and Fieldmate by Yokogawa • FieldCare by Endress + Hauser • FDM by Honeywell • etc.
Characteristic values		
Maximum internal signal delay of the system; (without I/O module delay) for 8 I/O modules		
for Digital Input or Digital Output Modules	7 ms	7 ms
for Analog Input or Analog Output Modules	10 ms	10 ms
MTBF according to SN 29500	29 years (at 40 °C / 104 °F)	29 years (at 40 °C / 104 °F)
Operator interface		
Operation	LED green "RUN"	LED green "RUN"
Fault	LED red "ERR"	LED red "ERR"
LCD indication	2 x 16 characters	2 x 16 characters
Settings	bus address	bus address
Indications	at any time: Bus addresses, alarms / faults, information (type, revision, etc.) for the levels: field station, modules and signals, values of the inputs and outputs	at any time: Bus addresses, alarms / faults, information (type, revision, etc.) for the levels: field station, modules and signals, values of the inputs and outputs

Technical Data		
Types	9440/22-01-11 (24 V DC)	9440/22-01-21 (90 ... 253 V AC)
Diagnostics		
CPU & Power Module	<ul style="list-style-type: none"> • Hardware fault • Configuration fault 	<ul style="list-style-type: none"> • Hardware fault • Configuration fault
I/O Modules	<ul style="list-style-type: none"> • Internal primary bus faults • Internal redundant bus faults • No response • Module does not correspond to configuration • Hardware fault 	<ul style="list-style-type: none"> • Internal primary bus faults • Internal redundant bus faults • No response • Module does not correspond to configuration • Hardware fault
Further I/O module fault indications	See data sheets for the I/O modules	See data sheets for the I/O modules
Power supply for the I/O modules via the BusRail		
Voltage range	22.5 ... 26.2 V DC	22.5 ... 26.2 V DC
Maximum current	2 A	2 A
Maximum number of the I/O modules	8	8
Redundant supply of the I/O modules	yes (decoupled with diodes)	yes (decoupled with diodes)
Undervoltage monitoring	yes	yes
Power supply		
Nominal voltage	24 V DC	120 V / 230 V, AC
Voltage range	20 ... 35 V DC	90 ... 253 V AC
Mains frequency	--	50 / 60 Hz
Frequency range	--	45 ... 66 Hz
Current consumption without I/O modules	approx. 0.21 A at 24 V DC	approx. 25 mA at 230 V AC or approx. 48 mA at 120 V AC
Actual current consumption with 8 I/O modules	approx. 2.5 A at 24 V DC	approx. 0.4 A at 230 V AC, approx. 0.8 A at 120 V AC
Power dissipation without I/O modules	5 W	8.4 W
per connected I/O module	approx. 1.4 W	approx. 1 W
Reverse polarity protection	yes	not applicable
Defined behaviour at undervoltage	yes	yes
Mechanical data		
Module enclosure	Polyamide 6GF	Polyamide 6GF
Fire protection class (UL 94)	HB	HB
Degree of protection (IEC 60529)		
Modules	IP30	IP30
Connections	IP20	IP20
Electrical connection		
Fieldbus RS 485	Sub-D socket 9-pin	Sub-D socket 9-pin
ServiceBus RS 485	Sub-D socket 9-pin	Sub-D socket 9-pin
CPU & Power Module Zone 1 / Division 1	Ex e terminals 4.0 mm ² / 10 AWG; for Division 1 there is a special socket available connected by means of conduit	Ex e terminals 4.0 mm ² / 10 AWG; for Division 1 there is a special socket available connected by means of conduit
Galvanic isolation		
between power supply and system components	1500 V AC	1500 V AC
between Fieldbus/ServiceBus interface and system components	500 V AC	500 V AC
between two bus interfaces	500 V AC	500 V AC
Installation conditions		
Mounting type	on 35 mm DIN rail NS 35/15	on 35 mm DIN rail NS 35/15
Installation position	horizontal and vertical	horizontal and vertical

Technical Data		
Types	9440/22-01-11 (24 V DC)	9440/22-01-21 (90 ... 253 V AC)
Ambient conditions		
Ambient temperature	- 20 ... + 65 °C / - 4 ... + 149 °F	- 20 ... + 65 °C / - 4 ... + 149 °F
Storage temperature	- 40 ... + 70 °C / - 40 ... + 158 °F	- 40 ... + 70 °C / - 40 ... + 158 °F
Maximum relative humidity	95 % (no condensation)	95 % (no condensation)
Vibration, sinusoidal (IEC EN 60068-2-6)	1 g in frequency range between 10 ... 500 Hz 2 g in frequency range 45 ... 100 Hz	1 g in frequency range between 10 ... 500 Hz 2 g in frequency range 45 ... 100 Hz
Shock, semi-sinusoidal (IEC EN 60068-2-27)	15 g (3 shocks per axis and direction)	15 g (3 shocks per axis and direction)
Electromagnetic compatibility	Tested according to the following standards and regulations: EN 61326-1 (1998) IEC 1000-4-1...6, NAMUR NE 21	Tested according to the following standards and regulations: EN 61326-1 (1998) IEC 1000-4-1...6, NAMUR NE 21

Accessories and Spare Parts			
Designation	Illustration	Description	Order number
SUB-D socket	 09868E00	9-pin for connection of the fieldbus or ServiceBus to the CPU & power module Series 9440/22 and fieldbus-isolating repeater 9185. Integrated terminator can be switched on or off. For RS 485 IS (according to PNO standard)	162693
Optical fieldbus-isolating repeater, Zone 1 / Div. 1	 11131E00	<ul style="list-style-type: none"> • Isolating repeater for installation in Zone 1 and Zone 2 / Class I Division 2 and Class I Zone 1 • For fieldbus via fibre optic intrinsically safe cables „ex op is“ into Zone 1 / Class I, II, III Division 1 and Class I, II, III Zone 0 • Redundant construction possible using optical ring • Extensive diagnostic function and fault-contact • Suitable for Profibus DP up to 1.5 MBit/s • Further versions and information see data sheet of Series 9186 optical fieldbus-isolating repeater 	9186/12-11-11
Optical fieldbus-isolating repeater, Zone 2 / Div. 2	 11550E00	<ul style="list-style-type: none"> • Isolating repeater for installation in Zone 2 / Div. 2 • For fieldbus via fibre optic intrinsically safe cables „ex op is“ into Zone 1 / Div. 1 • Optical ring possible • Extensive diagnostic function and fault-contact • Suitable for Profibus DP up to 1.5 MBit/s • Further versions and information see data sheet of Series 9186 optical fieldbus-isolating repeater 	9186/15-12-11
	 11550E00	<ul style="list-style-type: none"> • Isolating repeater for installation in Zone 2 / Div. 2 • For fieldbus via fibre optic intrinsically safe cables „ex op is“ into Zone 1 / Div. 1 • Point-to-point or line structure • Extensive diagnostic function and fault-contact • Suitable for Profibus DP up to 1.5 MBit/s • Further versions and information see data sheet of Series 9186 optical fieldbus-isolating repeater 	9186/25-12-11
Fieldbus-isolating repeater, up to 1.5 MBit/s, for application in safe areas (non-Ex) or Zone 2 / Div. 2	 09867E00	<ul style="list-style-type: none"> • Equipment for installation in safe areas or Zone 2 / Div. 2 • For fieldbusses with RS 485 interface - Zone 1 / Class I, II, III Division 1 and Class I, II, III Zone 1 • Suitable for Profibus DP, Modbus, R. STAHL ServiceBus • Interface to automation system RS 232, RS 422, RS 485 • Automatic setting of transfer rate for Profibus DP • Adjustable transfer rate (1.2 kBit/s to 1.5 MBit/s) • Power supply 24 V AC/DC • Further information see data sheet Series 9185/11 	9185/11-35-10s



Dimensional Drawings (All Dimensions in mm / inches) - Subject to Alterations

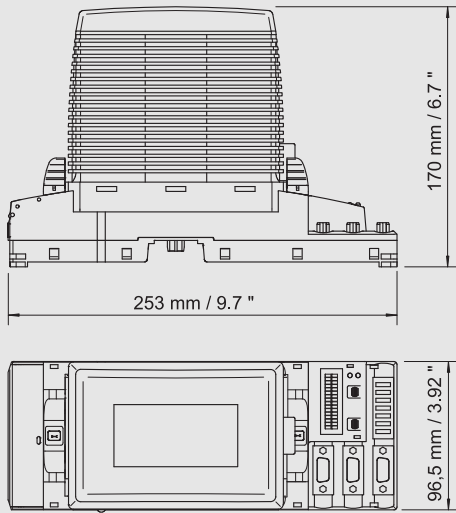

**CPU & Power Module for Zone 1
with connection by means of Ex e terminals**

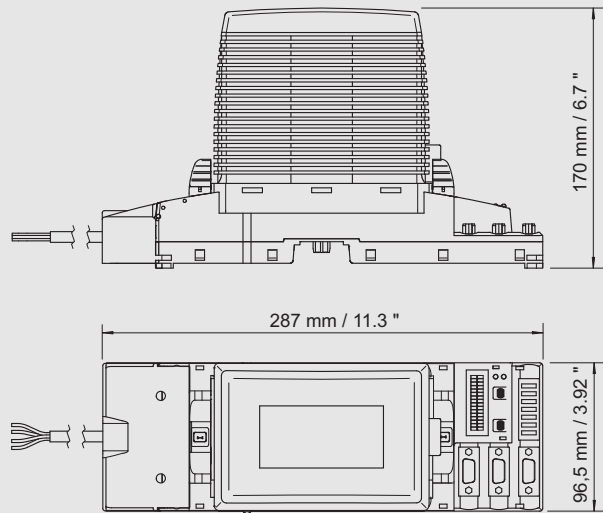

**CPU & Power Module for Division 1
with connection by means of a conduit**

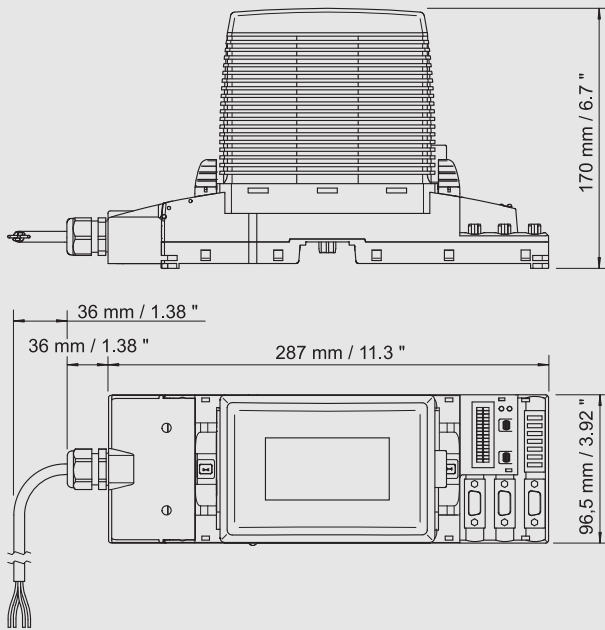

**CPU & Power Module for Zone 1
with connection by means of a pig tail**

We reserve the right to make alterations to the technical data, dimensions, weights, designs and products available without notice. The illustrations cannot be considered binding.

