

06974E00

### Fibre Optics Fieldbus Isolating Repeater for Installation in Zone 2 Type 9186/5

- Easy installation and maintenance due to:
  - Intrinsically safe optical interface
  - Intrinsically safe bus connection via RS 485 IS (PNO)
- High availability due to:
  - Build-up of ring structures, redundant Point-to-Point, line structures
  - Integrated analysis of optical input signal
  - Error message if critical levels of input signal reached
- Transmission of Profibus DP, Modbus, HART on RS 485, R. STAHL Servicebus



The Fibre Optic Isolating Repeater is used to build-up fibre optic network structures in hazardous areas. It enables to transmit Profibus DP or Modbus signals over distances of up to 2 km or 1.2 miles. The optical interfaces are designed to be inherently safe (Ex op is) acc. to IEC EN 60079-28. This approach reduces the installation and maintenance effort of fibre optic lines in hazardous areas dramatically. The transmitted optical signal is energy limited in a way which does not allow to ignite hazardous atmosphere. The protection scheme Ex op is allows to apply usual standardized industry connectors. Furthermore an operator may connect or disconnect the optical line without switching off the transmitter in prior. The Zone 1 / Div. 2 version of the Fibre Optic Isolating Repeater offers an intrinsically safe RS 485 interface acc. to the standard RS 485 IS (PNO), enabling once more a facilitated installation and maintenance.

Critical levels of the received optical signal are detected by the integrated diagnostic function. The fault is indicated by LEDs on the front side of the device and in addition by a line fault contact. The contact is used to trigger a remote fault indication in the control room. The diagnostic function enables preventive maintenance and improves the availability of the plant.

By means of the Fibre Optic Isolating Repeater various network structures may be build-up. Beside the well-know point-to-point structure the user may build-up redundant ring structures, offering an unmatched availability of the bus signal.

	Zones					
	0	1	2	20	21	22
RS 485 interfaces						
Installation in			X			X
LWL interface	X	X	X	X	X	X

## Selection Table

Version	Network structure	Installation in	Order number
Fibre optics fieldbus isolating repeater Type 9186/5	Point-to-point, end of line	<b>Zone 2 and in safe area</b>	<b>9186/25-12-11</b>
	Ring, point-to-point redundant, line	<b>Zone 2 and in safe area</b>	<b>9186/15-12-11</b>

## Technical Data

Version	<b>9186/5</b>
Installation in	<b>Zone 2 and in safe area</b>
Certificates	BVS 07 ATEX 068 X
Explosion protection	 II (1) GD [Ex op is] IIC  II 3 G Ex nA nC II T4
Safety data (CENELEC)	
Fibre optic interface	conform to Ex op is acc. to EN 60079-28
max. radiated power $P_o$	$\leq 15$ mW Further information and combinations of values, see certification
Power supply	
Nominal voltage $U_N$	24 V DC
Voltage range	18 V ... 31.2 V
Residual ripple	< 3.6 V <sub>ss</sub>
Nominal current (at $U_N$ )	130 mA
Power consumption	3 W
Indication	green LED "PWR"
Polarity reversal protection	yes
Galvanic transmission	
between RS 485 and power supply	$\geq 1.5$ kV
Optical interface	
Protocols	protocol transparent to RS-485 interface
Network topologies	ring structure, line structure, point-to-point connection
Redundancy	automatic switchover triggered by line fault
Connection	ST®, BFOC/2.5 socket
Wave length	850 nm
Transmission line length	$\leq 2000$ m
Recommended fibre optic cables	G 50 / 125 G 62.5 / 125
	Integrated diagnostic function with alarming and automatic switch-over to the protection path, improves the availability. Only version 9186/15-12-11
Electrical interface	
Protocols	Profibus DP, Modbus, HART, ServiceBus R.STAHL (IS1)
Version	RS 485
Connection	Sub-D socket X1, 9-pole
Transmission speed	9.6 kBit/s ... 1.5 Mbit/s
Settings	Set-up of fixed transmission speed or automatic detection (only with Profibus DP)
Bit refresh	Received bit is restored
Cable length	according to Profibus guideline, depends on transmission speed and cable
Transmission	2-wire, half duplex
Terminating resistor	to be set in external plug
Indication received Data	LED green "RD" ON
Indication transmitted data	LED yellow "TD" ON

## Fibre Optics Fieldbus Isolating Repeater for Installation in Zone 2 Type 9186/5

### Technical Data

<b>Fault monitoring</b>	
Power supply failure	LF signalisation contact open
Input signal level good	LED green and yellow "FO Signal", LF signalisation contact closed
Input signal level reduced (- 1.5 dBm)	LED yellow "FO Signal", LF signalisation contact open
Break of fibre or Input signal level too low (- 3 dBm)	LED red "FO ERR", LF signalisation contact open
Max. load of the contact	max. 60 V DC, 42 V, 1 A
<b>Electromagnetic compatibility</b>	Tested under the following standards and regulations: EN 61326-1 Use in industrial environment
<b>Ambient conditions</b>	
Ambient temperature	- 20 °C ... + 60 °C
Storage temperature	- 40 °C ... + 85 °C
Relative humidity (no condensation)	≤ 95 %
<b>Connectors</b>	
Powersupply	Screw terminal, 0,2 ... 2,5 mm <sup>2</sup> green
Error contact	Screw terminal, 0,2 ... 2,5 mm <sup>2</sup> green
Shield connection to PA	via DIN rail contact
Serial connection	Sub-D socket X1, 9-pole
Shielding	Via Sub-D socket
Fibre type	BFOC/2.5 for glas fibre 50/125, 62.5/125
<b>Mechanical data</b>	
Weight	approx.200 g
Installation	on DIN rail, EN 50022 (NS35/15; NS35/7.5)
<b>Protection</b>	
Casing	IP30
Terminals Powersupply	IP30
Terminals	IP30
Enclosure material	PA 6.6
Fire protection class (UL-94)	V0
<b>Connection diagram</b>	<b>9186/15-...-</b>

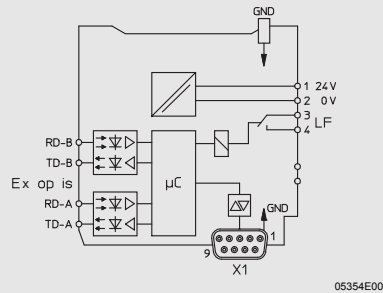

PIN	RS 485
8	A -
3	B +
6	U +
5	GND

**9186/25-...-**

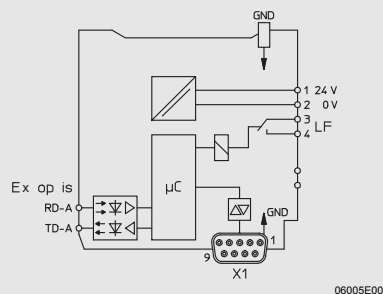

PIN	RS 485
8	A -
3	B +
6	U +
5	GND



### Dimensional Drawings (All Dimensions in mm) - Subject to Alterations

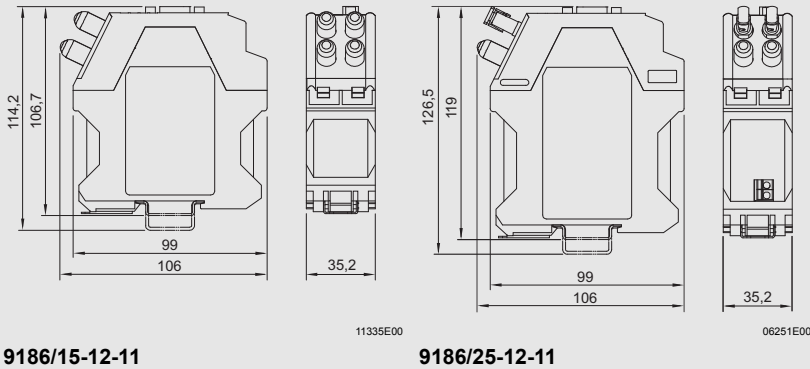

### Network-topology

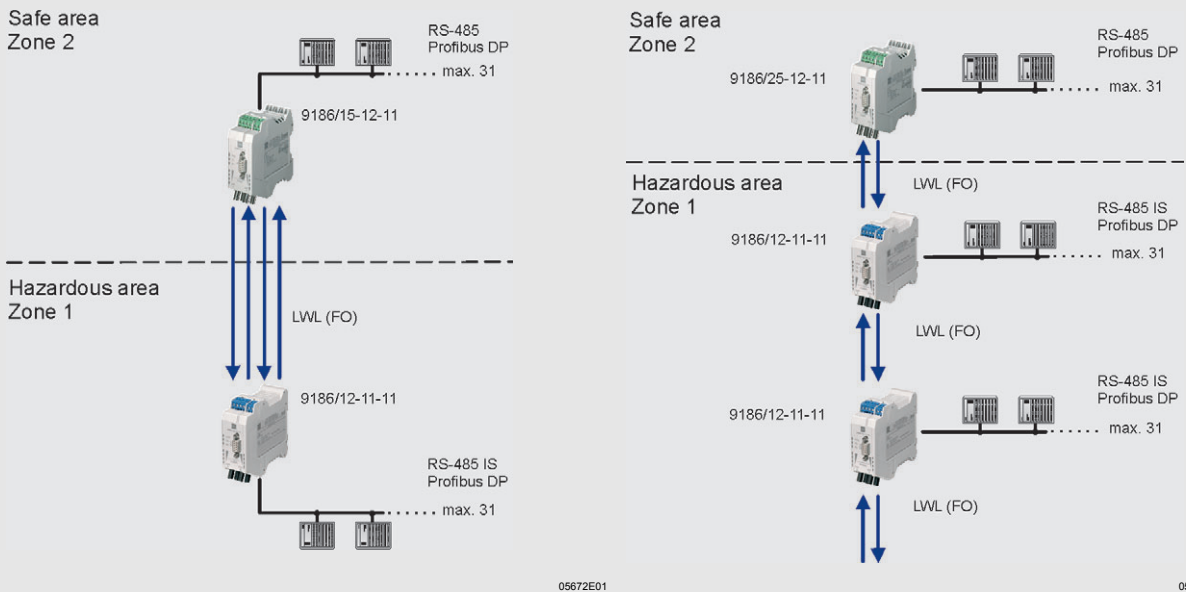

### Point-to-Point structure

### Line structure

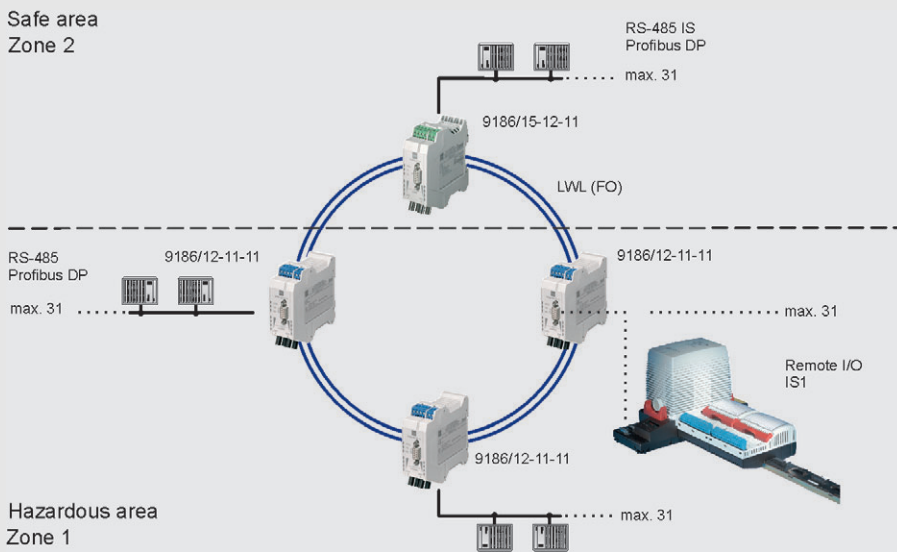

### Ring structure

We reserve the right to make alterations to the technical data, weights, dimensions, designs and products available without notice. The illustrations cannot be considered binding.

